

Pipeline Valves & Fittings



Gate Valves

Check Valves

Strainers

Couplings

Flanges

Fittings



almanit sanitary fittings
Wartenau 7 22089 Hamburg Germany



Contents

DIN Gate Valves	2-5
DIN Globe Valves & Strainers	6
DIN Check Valves	7
BS Gate Valves	8-11
BS Check Valves & Strainers	12-13
ANSI Gate Valves	14-16
ANSI Check Valves	17
GB Valves	18-21
Electric / Gear Valves	22
Check Valves	23-25
Butterfly Valves	26-28
Expansion Joints	29-30
Couplings	31-37
Saddles & Clamps	38-39
Flanges	40-48
Cast Iron Fittings	49-62

RSV NO.02 (A)

Non-rising stem resilient soft seated gate valves DIN 3352-F4

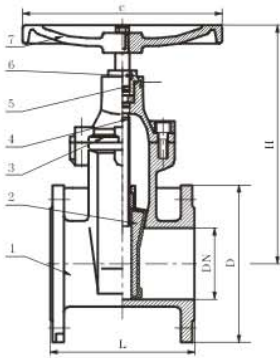

Components

1	Body	Cast iron or ductile iron
2	Disc	Ductile iron with NBR/EPDM
3	Bonnet	Cast iron or Ductile iron
4	Stem	Stainless steel
5	O-ring	NBR
6	Nut	Brass
7	Hand wheel	Cast iron or Ductile iron

Application

1	Face to face is according to DIN3202-F4
2	Flange drilled is according to DIN2532/2533

Test

Working pressure	PN10	PN16
Shell pressure	15bars	24bars
Seat pressure	11bars	17.6bars

Dimensions

unit: mm

DN	50	65	80	100	125	150	200	250	300
L	150	170	180	190	200	210	230	250	270
H	255	315	320	370	475	495	550	650	735
D (PN10)	165	185	200	220	250	285	340	405	460
D (PN16)	165	185	200	220	250	285	340	405	460
C	200	200	250	250	320	320	350	400	400

RSV NO.02 (B)

Non-rising stem resilient soft seated gate valves DIN 3352-F5

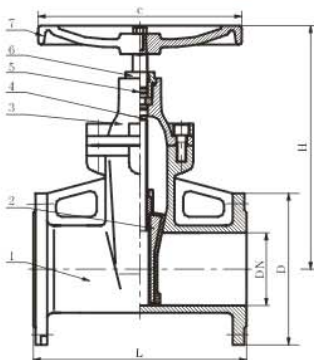

Components

1	Body	Cast iron or ductile iron
2	Disc	Ductile iron with NBR/EPDM
3	Bonnet	Cast iron or Ductile iron
4	Stem	Stainless steel
5	O-ring	NBR
6	Nut	Brass
7	Hand wheel	Cast iron or Ductile iron

Application

1	Face to face is according to DIN3202-F5
2	Flange drilled is according to DIN2532/2533

Test

Working pressure	PN10	PN16
Shell pressure	15bars	24bars
Seat pressure	11bars	17.6bars

Dimensions

unit: mm

DN	50	65	80	100	125	150	200	250	300
L	250	270	280	300	325	350	400	450	500
H	280	315	340	370	475	495	550	650	735
D (PN10)	165	185	200	220	250	285	340	405	460
D (PN16)	165	185	200	220	250	285	340	405	460
C	200	200	250	250	320	320	350	400	400

Non-rising stem gate valves DIN 3352-F4 "A" type

RSV NO.03 (A)

Components

1	Body	Cast iron or ductile iron
2	Disc	Cast iron or Ductile iron
3	Seat	Brass/Stainless steel
4	Stem	Stainless steel
5	Bonnet	Cast iron or Ductile iron
6	O-ring	NBR
7	Hand wheel	Cast iron or Ductile iron

Application

1	Face to face is according to DIN3302-F4
2	Flange drilled is according to DIN2532/2533
3	Nominal pressure PN10/PN16

Test

Working pressure	10bars	16bars
Shell pressure	15bars	24bars
Seat pressure	11bars	17.6bars

Dimensions

unit:mm

DN	40	50	65	80	100	125	150	200	250	300
L	140	150	170	180	190	200	210	230	250	270
H	276	296	330	343	372	463	480	603	729	774
C	200	200	200	250	250	320	320	350	400	400
D (PN10)	150	165	185	200	220	250	285	340	395	445
D (PN16)	150	165	185	200	220	250	285	340	405	460

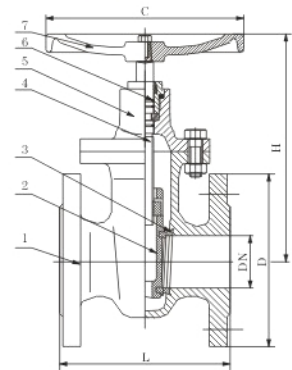

Non-rising stem type gate valves DIN 3352-F5

RSV NO.03 (B)

Components

1	Body	Cast iron or ductile iron
2	Disc	Cast iron or Ductile iron
3	Seat	Brass/Stainless steel
4	Stem	Stainless steel
5	Bonnet	Cast iron or Ductile iron
6	Hand wheel	Cast iron or Ductile iron

Application

1	Face to face is according to DIN3202-F5
2	Flange drilled is according to DIN2532/2533
3	Nominal pressure PN10/PN16

Test

Working pressure	10bars	16bars
Test pressure Shell	15bars	24bars
Seat	11bars	17.6bars

Dimensions

unit:mm

DN	40	50	65	80	100	125	150	200	250	300
L	240	250	270	280	300	325	350	400	450	500
H	276	296	330	343	372	463	480	603	729	774
C	200	200	200	250	250	320	320	350	400	400
D (PN10)	150	165	185	200	220	250	285	340	395	445
D (PN16)	150	165	185	200	220	250	285	340	405	460

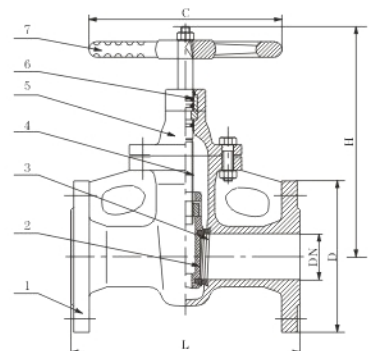

RSV NO.04 (A)

Non-rising stem gate valves DIN 3352-F4 "B" type

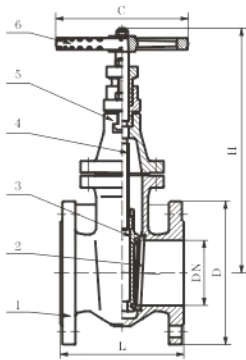

Components

1	Body	Cast iron or ductile iron
2	Disc	Cast iron or ductile iron
3	Seat	Brass
4	Stem	Stainless steel
5	Bonnet	Cast iron or Ductile iron
6	Hand wheel	Cast iron or Ductile iron

Application

1	Face to face is according to DIN3302-F4
2	Flange drilled is according to DIN2532/2533
3	Nominal pressure PN10/PN16

Test

Working pressure	10bars	16bars
Test pressure Shell	15bars	24bars
Seat	11bars	17.6bars

Dimensions

	unit:mm									
DN	40	50	65	80	100	125	150	200	250	300
L	140	150	170	180	190	200	210	230	250	270
H	276	296	330	343	372	463	480	603	729	774
C	200	200	200	250	250	320	320	350	400	400
D (PN10)	150	165	185	200	220	250	285	340	395	445
D (PN16)	150	165	185	200	220	250	285	340	405	460

RSV NO.04 (B)

Non-rising stem type gate valves DIN 3352-F4 "O" type

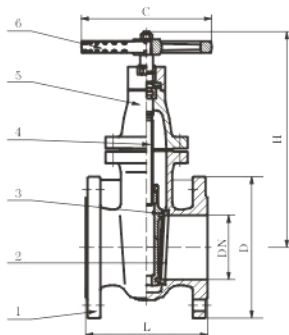

Components

1	Body	Cast iron or ductile iron
2	Seat	Brass
3	Disc	Cast iron or ductile iron
4	Stem	Stainless steel
5	Bonnet	Cast iron or Ductile iron
6	Hand wheel	Cast iron or Ductile iron

Application

1	Face to face is according to DIN3302-F4
2	Flange drilled is according to DIN2532/2533
3	Nominal pressure PN10/PN16

Test

Working pressure	10bars	16bars
Test pressure Shell	15bars	24bars
Seat	11bars	17.6bars

Dimensions

	unit:mm									
DN	40	50	65	80	100	125	150	200	250	300
L	140	150	170	180	190	200	210	230	250	270
H	212	236	262	292	336	400	438	552	668	714
C	200	200	200	250	250	320	320	350	400	400
D (PN10)	150	165	185	200	220	250	285	340	395	445
D (PN16)	150	165	185	200	220	250	285	340	405	460

Rising stem resilient soft seated gate valves DIN 3352-F4

RSV NO.05 (A)

Components

1	Body	Cast iron or Ductile iron
2	Seat	Brass/stainless steel
3	Disc	Cast iron or Ductile iron
4	Stem	stainless steel
5	Bonnet	Cast iron or Ductile iron
6	Hand wheel	Cast iron or Ductile iron

Application

1	Structural Formation	BB-BG-OS&Y
2	Driving Manner	Hand-Operated Electric-Actrated
3	Design Standard	DIN3352
4	Face to Face	DIN3202
5	Flange Ends	DIN2543-2547
6	Flange Ends Test&Inspection	DIN3230

Test

Nominal Pressure(MPa)	1.6	2.5	4.0	6.4
Shell Test(MPa)	2.4	3.75	6.0	9.6
Sealing Test(MPa)	1.76	2.75	4.4	7.04
Suitable Temp(°C)	-110~600°C			
Suitable Medium	Water Oil&Gas			

Dimensions

unit:mm

DN	40	50	65	80	100	125	150	200	250	300
L	200	230	290	310	350	400	480	600	730	850
H	235	250	285	335	370	435	475	555	650	695
C	200	200	200	250	250	320	320	400	520	520

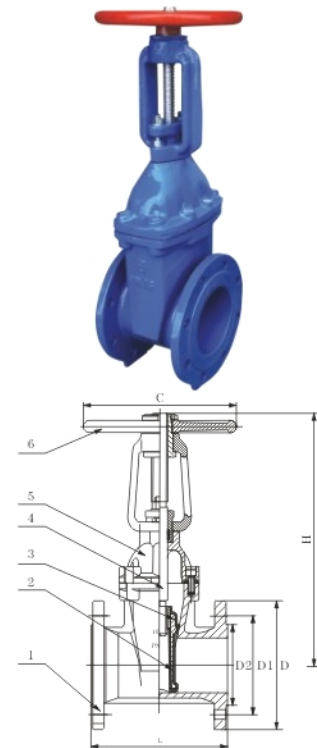

Globe valves DIN 3202-F1

RSV NO.05 (B)

Components

1	Body	Cast iron or Ductile iron
2	Seat	Brass/stainless steel
3	Disc	Cast iron or Ductile iron
4	Stem	stainless steel
5	Bonnet	Cast iron or Ductile iron
6	Hand wheel	Cast iron or Ductile iron

Application

1	Face to face is according to DIN3202-F1
2	Flange drilled is according to DIN2532/2533
3	Normal Pressure PN10/PN16

Test

Working pressure	PN10	PN16
Test pressure Shell	15bars	24bars
Seat	11bars	17.6bars

Dimensions

unit:mm

DN	15	20	25	32	40	50	65	80	100	125	150	200	250	300
L	130	150	160	180	200	230	290	310	350	400	480	600	730	850
H	165	180	195	205	235	250	285	335	370	435	475	555	650	695
C	100	100	120	120	160	200	200	240	240	280	280	400	520	520
D(PN10)	95	105	115	140	150	165	185	200	220	250	285	340	395	445
D(PN16)	95	105	115	140	150	165	185	200	220	250	285	340	405	460

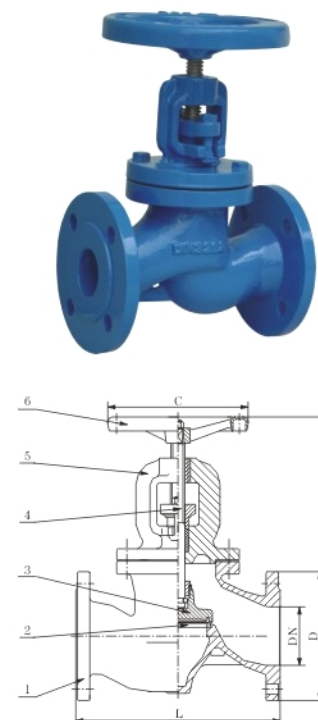

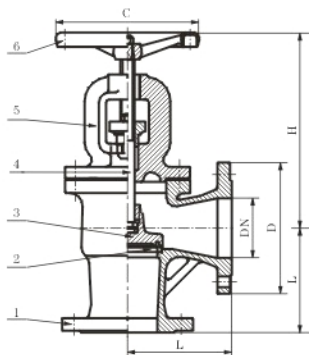
Components

1	Body	Cast iron or Ductile iron
2	Seat	Brass/Stainless steel
3	Disc	Cast iron or Ductile iron
4	Stem	stainless steel
5	Bonnet	Cast iron or Ductile iron
6	Hand wheel	Cast iron or Ductile iron

Application

1	Face to face is according to DIN3202-F32
2	Flange drilled is according to DIN2532/2533
3	Normal Pressure PN10/PN16

Test

Working pressure	PN10	PN16
Test pressure Shell	15bars	24bars
Seat	11bars	17.6bars

Dimensions

unit:mm

DN	15	20	25	32	40	50	65	80	100	125	150	200	250	300
L	90	95	100	105	115	125	145	155	175	200	225	275	325	375
H	165	180	195	205	235	250	285	335	370	435	475	555	650	695
C	100	100	120	120	160	200	200	240	240	280	280	400	520	520
D(PN10)	95	105	115	140	150	165	185	200	220	250	285	340	395	445
D(PN16)	95	105	115	140	150	165	185	200	220	250	285	340	405	460

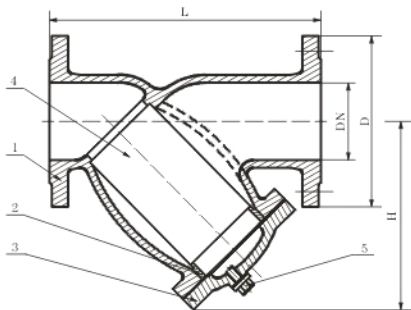
Components

1	Body	Cast iron or Ductile iron
2	Plug	Cast iron or Ductile iron
3	Cover	Cast iron or Ductile iron
4	Screen	stainless steel
5	Bolt	Carbon steel

Application

1	Face to face is according to DIN3202-F1
2	Flange drilled is according to DIN2532/2533

Test

Working pressure	PN10	PN16
Test pressure Shell	15bars	24bars
Seat	11bars	17.6bars

Dimensions

unit:mm

DN	40	50	65	80	100	125	150	200	250	300
L	200	230	290	310	350	400	480	600	730	850
H	105	125	150	175	195	235	275	350	420	490
D (PN10)	150	165	185	200	220	250	285	340	395	445
D (PN16)	150	165	185	200	220	250	285	340	405	460

Check valves DIN 3202-F6

RSV NO.07 (A)

Components

1	Body	Cast iron or ductile iron
2	Seat	Brass
3	Disc Seal Ring	Rubber/Brass
4	Disc	Cast iron or iron
5	Ingo pin	stainless steel
6	Bonnet	Cast iron or ductile iron



Application

1	Face to face is according to DIN3202-F6
2	Flange drilled is according to DIN2532/2533
3	Nominal Pressure PN10/PN16

Test

Working pressure	10bars	16bars
Shell pressure	15bars	24bars
Seat pressure	11bars	17.6bars

Dimensions

unit:mm

DN	40	50	65	80	100	125	150	200	250	300
L	180	200	240	260	300	350	400	500	600	700
H	120	125	130	160	185	195	205	285	320	340
D (PN10)	150	165	185	200	220	250	285	340	395	445
D (PN16)	150	165	185	200	220	250	285	340	405	460

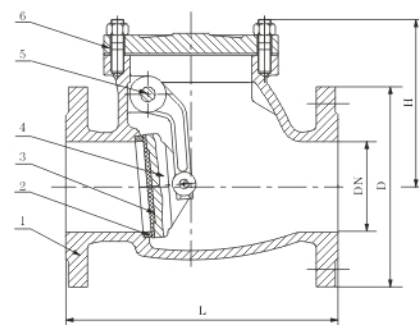

Check valves DIN 3202-F1

RSV NO.07 (B)

Components

1	Body	Cast iron or Ductile iron
2	Disc	Cast iron or Ductile iron
3	Bonnet	Cast iron or Ductile iron



Application

1	Face to face is according to DIN3202-F1
2	Flange drilled is according to DIN2532/2533
3	Nominal Pressure PN10/16

Test

Working pressure	10bars	16bars
Shell pressure	15bars	24bars
Seat pressure	11bars	17.6bars

Dimensions

unit:mm

DN	40	50	65	80	100	125	150	200	250	300
L	200	230	290	310	350	400	480	600	730	850
H	95	100	115	135	145	160	180	270	320	350
D (PN10)	150	165	185	200	220	250	285	340	395	445
D (PN16)	150	165	185	200	220	250	285	340	405	460

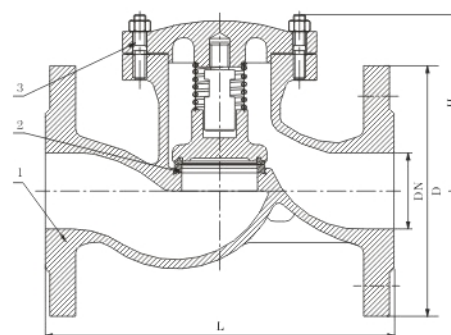

Non-rising stem resilient soft seated gate valves BS 5163

RSV NO.09 (A)

Components

1	Body	Cast iron or ductile iron
2	Disc	Ductile iron with NBR/EPDM
3	Bonnet	Cast iron or Ductile iron
4	Stem	Stainless steel
5	O-ring	NBR
6	Gland	Cast iron or Ductile iron
7	Hand wheel	Cast iron or Ductile iron

Application

1	Face to face is according to BS5163:1986
2	Flange drilled is according to BS4504

Test

Working pressure	PN10	PN16
Shell pressure	15bars	24bars
Seat pressure	11bars	17.6bars

Dimensions

unit:inch

DN	2"	2-1/2"	3"	4"	5"	6"	8"	10"	12"
L	7"	7-1/2"	8"	9"	10"	10-1/2"	11-1/2"	13"	14"
H	11"	15-1/5"	11-3/5"	12-4/5"	14-4/5"	16-9/10"	21"	24-1/5"	27-1/5"
C	7-9/10"	7-9/10"	9-4/5"	11"	12-3/5"	12-3/5"	13-4/5"	16"	17-7/10"
D	6-1/2"	7-3/10"	7-9/10"	8-7/10"	10"	11"	13-4/5"	16"	18"

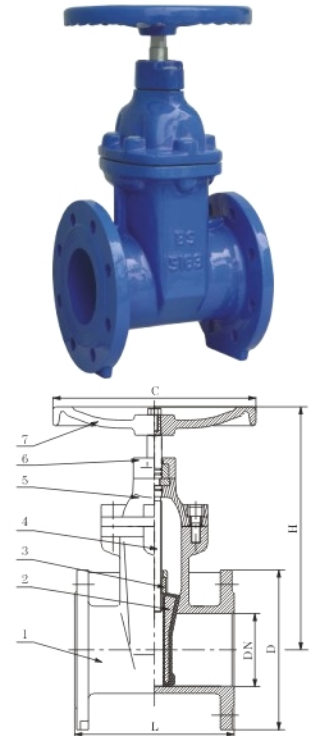

Non-rising stem, socket end gate valves ,resilient soft seated

RSV NO.09 (B)

Material

Body	Cast iron/ductile iron
Bonnet	Cast iron/ductile iron
Wedge	Cast iron/ductile iron with NBR/EPDM
Stem	Stainless steel/brass
Bolt & Nut	Stainless steel/steel with zinc

Design

Face to face is according to BS,DIN,ANSI,AWWA, SABS standard etc.

Test

Working pressure	PN10	PN16
Shell pressure	PN15	PN24
Seat pressure	PN11	PN17.6

Dimension

Unit:mm

Size(DN)	40	50	65	80	100	125	150	200	250	300
L	240	250	270	280	300	325	350	400	450	500
H	245	278	302	330	337	430	497	600	711	796

* Dimension Of "L" Can Be Design Acc To Buyer's Requested.

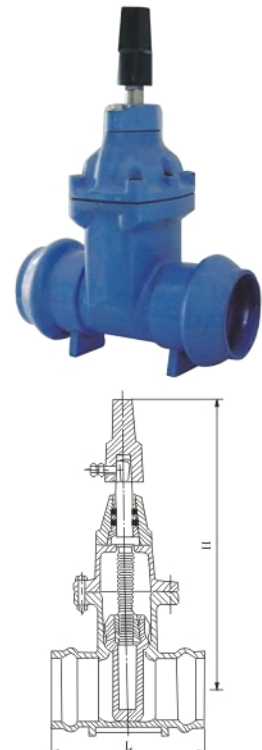

RSV NO.10 (A)

Non-rising stem gate valves BS 3464

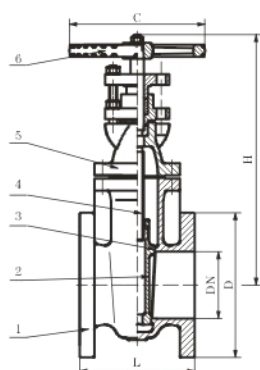

Components

1	Body	Cast iron or ductile iron
2	Disc	Cast iron or ductile iron
3	Seat	Cast iron or Brass
4	Stem	stainless steel or Brass
5	Bonnet	Cast iron or ductile iron
6	Hand wheel	Cast iron or ductile iron

Application

1	Face to face is according to BS3464
2	Flange drilled is according to BS 10Table E orD

Test

Working pressure	PN10	
Test pressure Shell	15bars	24bars
Seat	11bars	17.6bars

Dimensions

unit:mm

DN	40	50	65	80	100	125	150	200	250	300
L	140	146	159	165	172	190	210	241	273	305
H	212	236	262	292	336	400	438	552	668	714
C	152	152	152	203	229	229	229	229	337	337
D	135	152	165	184	216	254	254	337	406	457

RSV NO.10 (B)

Non-rising stem gate valves BS 5163

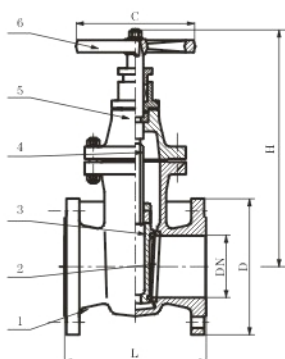

Components

1	Body	Cast iron or ductile iron
2	Seat	Brass/stainless steel
3	Disc	Cast iron or Ductile iron
4	Bonnet	Stainless steel
5	Stem	Cast iron or Ductile iron
6	Hand wheel	Cast iron or Ductile iron

Application

1	Face to face is according to BS5163:1986
2	Flange drilled is according to BS table E or D/BS4504

Test

Working pressure	PN16	
Test pressure Shell	15bars	24bars
Seat	11bars	17.6bars

Dimensions

unit:inch

DN	1-1/2"	2"	2-1/2"	3"	4"	5"	6"	8"	10"	12"
L	6-1/2"	7"	7-1/2"	8"	9"	10"	10-1/2"	11-1/2"	13"	14"
H	11"	11-1/4"	12-7/8"	14"	15-1/2"	17-1/4"	19-1/8"	25-7/8"	28-5/8"	32-1/2"
C	6"	7"	7"	7"	8"	10"	10"	12"	14"	16"
D	6"	6-1/2"	7-3/10"	7-9/10"	8-7/10"	10"	11"	13-4/5"	16"	18"

RSV NO.10 (A)

Non-rising stem gate valves BS 3464

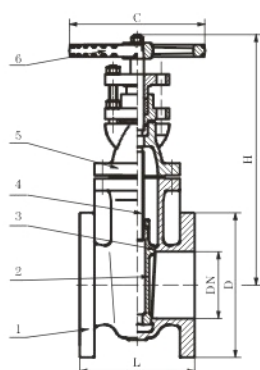

Components

1	Body	Cast iron or ductile iron
2	Disc	Cast iron or ductile iron
3	Seat	Cast iron or Brass
4	Stem	stainless steel or Brass
5	Bonnet	Cast iron or ductile iron
6	Hand wheel	Cast iron or ductile iron

Application

1	Face to face is according to BS3464
2	Flange drilled is according to BS 10Table E orD

Test

Working pressure	PN10	
Test pressure Shell	15bars	24bars
Seat	11bars	17.6bars

Dimensions

unit:mm

DN	40	50	65	80	100	125	150	200	250	300
L	140	146	159	165	172	190	210	241	273	305
H	212	236	262	292	336	400	438	552	668	714
C	152	152	152	203	229	229	229	229	337	337
D	135	152	165	184	216	254	254	337	406	457

RSV NO.10 (B)

Non-rising stem gate valves BS 5163

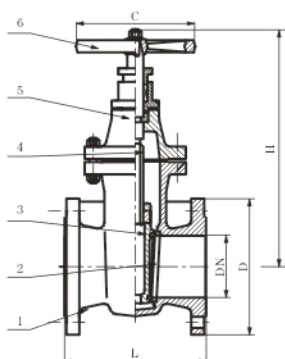

Components

1	Body	Cast iron or ductile iron
2	Seat	Brass/stainless steel
3	Disc	Cast iron or Ductile iron
4	Bonnet	Stainless steel
5	Stem	Cast iron or Ductile iron
6	Hand wheel	Cast iron or Ductile iron

Application

1	Face to face is according to BS5163:1986
2	Flange drilled is according to BS table E or D/BS4504

Test

Working pressure	PN16	
Test pressure Shell	15bars	24bars
Seat	11bars	17.6bars

Dimensions

unit:inch

DN	1-1/2"	2"	2-1/2"	3"	4"	5"	6"	8"	10"	12"
L	6-1/2"	7"	7-1/2"	8"	9"	10"	10-1/2"	11-1/2"	13"	14"
H	11"	11-1/4"	12-7/8"	14"	15-1/2"	17-1/4"	19-1/8"	25-7/8"	28-5/8"	32-1/2"
C	6"	7"	7"	7"	8"	10"	10"	12"	14"	16"
D	6"	6-1/2"	7-3/10"	7-9/10"	8-7/10"	10"	11"	13-4/5"	16"	18"

RSV NO.12 (A)

Rising stem gate valves BS 5150

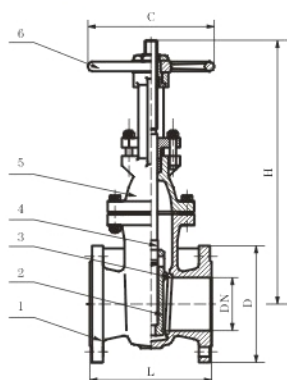

Components

1	Body	Cast iron or ductile iron
2	Disc	Cast iron or Ductile iron
3	Seat	Brass/stainless steel
4	Stem	Stainless steel
5	Bonnet	Cast iron or Ductile iron
6	Hand wheel	Cast iron or Ductile iron

Application

1	Face to face is according to BS5150
2	Flange drilled is according to BS4504

Test

Working pressure	PN16	
Test pressure Shell	15bars	24bars
Seat	11bars	17.6bars

Dimensions

unit:inch

DN	1-1/2"	2"	2-1/2"	3"	4"	5"	6"	8"	10"	12"
L	6-1/2"	7"	7-1/2"	8"	9"	10"	10-1/2"	11-1/2"	13"	14"
H	11-1/4"	12"	13-1/2"	15-3/8"	17-4/5"	21"	23-7/10"	32"	36-4/5"	42-5/8"
C	7"	7"	7"	8"	10"	10"	12"	14"	16"	18"
D	6"	6-1/2"	7-3/10"	7-9/10"	8-7/10"	10"	11"	13-4/5"	16"	18"

RSV NO.12 (B)

Globe valves BS 5152

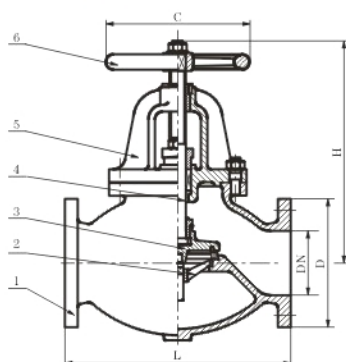

Components

1	Body	Cast iron or ductile iron
2	Seat	Bronze or Brass
3	Disc	Cast iron or ductile iron
4	Stem	Brass or stainless
5	Bonnet	Cast iron or ductile iron
6	Hand wheel	Cast iron or ductile iron

Application

1	Face to face is according to BS5152
2	Flange drilled is according to BS4504
3	Nominal pressure PN10/PN16

Test

Working pressure	PN10	PN16
Test pressure Shell	15bars	24bars
Seat	11bars	17.6bars

Dimensions

unit:inch

DN	2"	2-1/2"	3"	4"	5"	6"	8"	10"	12"
L	8"	8-1/2"	9-1/2"	11-1/2"	13"	14"	19-1/2"	24-1/2"	27-1/2"
H	10-3/4"	11-3/4"	12-1/4"	13-7/8"	14-3/4"	16-3/4"	20-1/4"	24-1/2"	30"
D	6-1/2"	7-3/10"	7-9/10"	8-7/10"	10"	11"	13-4/5"	16"	18"
C	7"	7"	8"	10"	10"	12"	14"	16"	18"

Check valves swing type BS5153

RSV NO.13 (A)

Components

1	Body	Cast iron or ductile iron
2	Seat	Brass
3	Disc	Cast iron or ductile iron
4	Hanger	Cast iron or ductile iron
5	Ingo pin	stainless steel
6	Bonnet	Cast iron or ductile iron

Application

1	Face to face is according to BS5153 PN10/PN16.
2	Flange drilled is according to BS4504 table E or D

Test

Working pressure	PN10	PN16
Test pressure Shell	15bars	24bars
Seat	11bars	17.6bars

Dimensions

unit:inch

DN	1-1/2"	2"	2-1/2"	3"	4"	5"	6"	8"	10"	12"
L	6-1/2"	8"	8-1/2"	9-1/2"	11-1/2"	13"	14"	19-1/2"	24-1/2"	27-1/2"
H	5"	5-1/8"	5-1/3"	6"	7-1/3"	7-3/4"	9-1/4"	11-1/4"	12"	13-7/8"
D (PN10)	6"	6-1/2"	7-3/10"	7-9/10"	8-7/10"	10"	11"	13-4/5"	15-1/2"	17-1/2"
D (PN16)	6"	6-1/2"	7-3/10"	7-9/10"	8-7/10"	10"	11"	13-4/5"	16"	18"

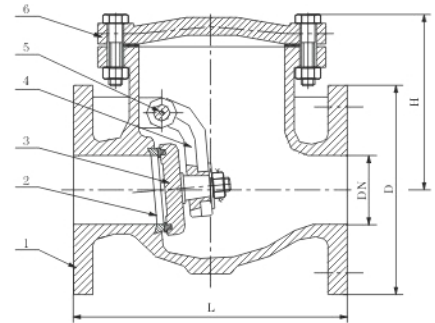

Check valves swing type BS 4090

RSV NO.13 (B)

Components

1	Body	Cast iron or ductile iron
2	Seat	Brass
3	Disc	Cast iron or ductile iron
4	Hanger	Cast iron or ductile iron
5	Ingo Pin	stainless steel
6	Bonnet	Cast iron or ductile iron

Application

1	Face to face is according to BS4090
2	Flange drilled is according to BS 10table E

Test

Working pressure	PN10
Test pressure Shell	15bars
Seat	11bars

Dimensions

unit:inch

DN	1-1/2"	2"	2-1/2"	3"	4"	5"	6"	8"	10"	12"
L	6-1/2"	8"	8-1/2"	9-1/2"	11-1/2"	13"	14"	19-1/2"	24-1/2"	27-1/2"
H	5"	5-1/8"	5-1/3"	6"	7-1/3"	7-3/4"	9-1/4"	11-1/4"	12"	13-7/8"
D	5-1/4"	6"	6-1/2"	7-1/5"	8-1/2"	10"	11"	13-3/10"	16"	18"

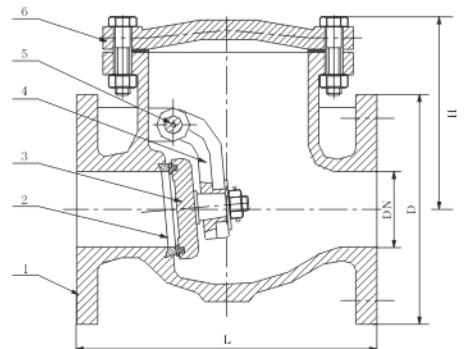

RSV NO.14 (A)

Strainers BS 4504

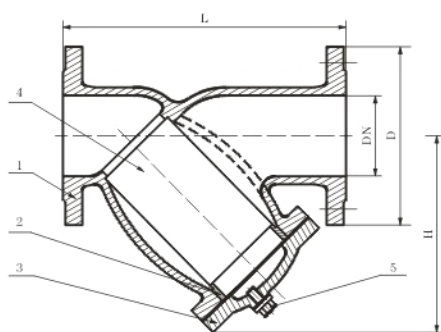

Components

1	Body	Cast iron or Ductile iron
2	Plug	Cast iron or Ductile iron
3	Cover	Cast iron or Ductile iron
4	Screen	Stainless steel
5	Blot	Carbon steel

Application

1	Face to face is according to BS2080
2	Flange drilled is according to BS4504

Test

Working pressure	PN16	
Shell pressure	15bars	24bars
Seat pressure	11bars	17.6bars

Dimensions

	unit:mm								
DN	50	65	80	100	125	150	200	250	300
L	220	270	290	350	390	440	540	660	720
H	120	140	170	220	260	300	360	440	525
D	165	185	200	220	250	285	340	405	460

RSV NO.14 (B)

Fire hydrants BS 750 PN16

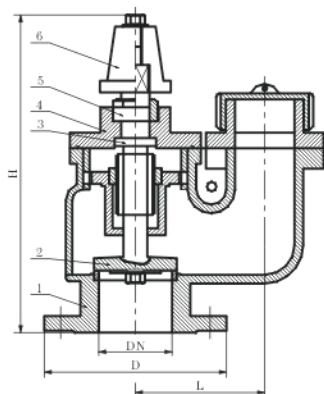

Components

1	Body	Cast iron or ductile iron
2	Disc	Cast iron or Ductile iron
3	Stem	Stainless
4	Bonnet	Cast iron or ductile iron
5	Bonnet nut	Brass or gunmetal
6	Operative	Cast iron or Ductile iron

Application

1	Flange end BS4504 PN16
2	Nominal pressure PN16

Test

Working pressure	PN16
Test shell pressure	24bars
Seat	17.6bars

Dimensions

	unit:inch				
DN	D	k	g	L	H
3"	7-7/8"	6-5/16"	5-7/16"	5-9/16"	14-11/16"

Rising stem resilient soft seated gate valves ANSI 125/150

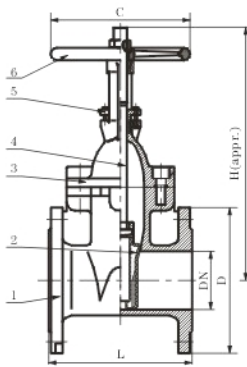

Components

1	Body	Cast iron or ductile iron
2	Disc	Ductile iron with NBR/EPDM
3	Bonnet	Cast iron or Ductile iron
4	Stem	Stainless steel
5	Gland	Cast iron or Ductile iron
6	Hand wheel	Cast iron or Ductile iron

Application

1	Face to face is according to ANSI B16.10
2	Flange drilled is according to ANSI B16.1/16.5
3	Class125 Flat face flange
4	Class150 Raised face flange

Test

Working pressure	125PSI	150PSI
Shell pressure	200PSI	
Seat pressure	300PSI	

Dimensions

unit:inch

DN	2"	2-1/2"	3"	4"	5"	6"	8"	10"	12"
L	7-1/64"	7-1/2"	8"	9"	10"	10-1/2"	11-1/2"	13"	14-1/64"
H	11-1/4"	13-1/2"	15-3/8"	17-4/5"	21"	23-7/10"	32"	36-4/5"	42-5/8"
D (PN10)	6"	7"	7-1/2"	9"	10"	11"	13-1/2"	16"	19"
D (PN16)	6"	7"	7-1/2"	9"	10"	11"	13-1/2"	16"	19"
C	7-9/10"	7-9/10"	9-4/5"	11"	12-3/5"	12-3/5"	13-4/5"	16"	17-7/10"

Non-rising stem, resilient soft seated gate valves ANSI 125/150

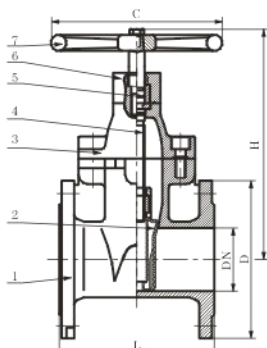

Components

1	Body	Cast iron or ductile iron
2	Disc	Ductile iron with NBR/EPDM
3	Bonnet	Cast iron or Ductile iron
4	Stem	Stainless steel
5	O-ring	NBR
6	Glang	Cast iron or Ductile iron
7	Hand wheel	Cast iron or Ductile iron

Application

1	Face to face is according to ANSI B16.10
2	Flange drilled is according to ANSI B16.1/16.5
3	Class125:Flat face flange
4	Class150:Raised face flange

Test

Working pressure	125PSI	150PSI
Shell pressure	200PSI	
Seat pressure	300PSI	

Dimensions

unit:inch

DN	2"	2-1/2"	3"	4"	5"	6"	8"	10"	12"
L	7-1/64"	7-1/2"	8"	9"	10"	10-1/2"	11-1/2"	13"	14-1/64"
H	11"	11-1/5"	11-3/5"	12-4/5"	14-4/5"	16-9/10"	21"	24-1/5"	27-1/5"
D125LBS	6"	7"	7-1/2"	9"	10"	11"	13-1/2"	16"	19"
D150LBS	6"	7"	7-1/2"	9"	10"	11"	13-1/2"	16"	19"
C	7-9/10"	7-9/10"	9-4/5"	11"	12-3/5"	12-3/5"	13-4/5"	16"	17-7/10"

Non-rising gate valves ANSI 125/150

RSV NO.17 (A)

Components

1	Body	Cast iron or ductile iron
2	Disc	Ductile iron with NBR/EPDM
3	Seat	Cast iron or ductile iron
4	Stem	Stainless steel
5	Glang	Cast iron or Ductile iron
6	Hand wheel	Cast iron or Ductile iron

Application

1	Face to face is according to ANSIB16.10
2	Flange drilled is according to ANSIB16.1/16.5
3	Class125:Flat face flange
4	Class150:Raised face flange

Test

Working pressure	125PSI	150PSI
Shell pressure	300PSI	
Seat pressure	200PSI	

Dimensions

unit: inch

DN	1-1/2"	2"	2-1/2"	3"	4"	5"	6"	8"	10"	12"
L	6-1/2"	7"	7-1/2"	8"	9"	10"	10-1/2"	11-1/2"	13"	14"
H	11"	11-1/4"	12-7/8"	14"	15-1/2"	17-1/4"	19-1/8"	25-7/8"	28-5/8"	32-1/2"
C	6"	7"	7"	7"	8"	10"	10"	12"	14"	16"
D	5"	6"	7"	7-12"	9"	10"	11"	13-1/2"	16"	19"

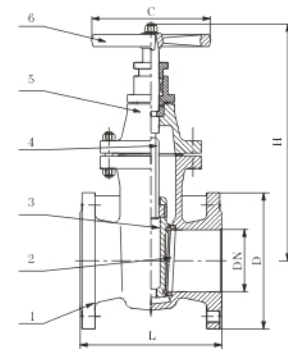

Rising stem ANSI 125/150 gate valves

RSV NO.17 (B)

Components

1	Body	Cast iron or ductile iron
2	Disc	Cast iron or ductile iron
3	Seat	Brass/Stainless steel
4	Stem	Stainless steel
5	Bonnet	Cast iron or Ductile iron
6	Hand wheel	Cast iron or Ductile iron

Application

1	Face to face is according to ANSIB16.10
2	Flange drilled is according to ANSIB16.1/16.5
3	Class125:Flat face flange
4	Class150:Raised face flange

Test

Working pressure	125PSI	150PSI
Test pressure shell	300PSI	
Seat	200PSI	

Dimensions

unit: inch

DN	1-1/2"	2"	2-1/2"	3"	4"	5"	6"	8"	10"	12"
L	6-1/2"	7"	7-1/2"	8"	9"	10"	10-1/2"	11-1/2"	13"	14"
H	11-1/4"	12"	13-1/2"	15-3/8"	17-4/5"	21"	23-7/10"	32"	36-4/5"	42-5/8"
C	7"	7"	7"	8"	10"	10"	12"	14"	16"	18"
D	5"	6"	7"	7-12"	9"	10"	11"	13-1/2"	16"	19"

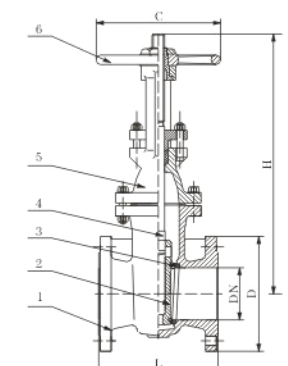

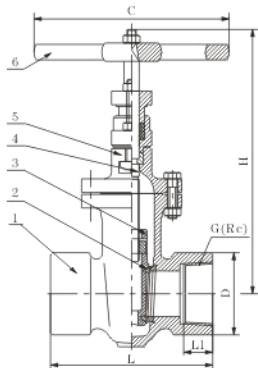
Components

1	Body	Cast iron or Ductile iron
2	Seat	Brass
3	Disc	Cast iron or Ductile iron
4	Stem	stainless steel
5	Bonnet	Cast iron or Ductile iron
6	Hand wheel	Cast iron or Ductile iron

Application

1	Face to face is according to MSS-SP-70
2	Nominal Pressure 125PSI

Test

Working pressure	125PSI
Shell pressure	300PSI
Seat pressure	200PSI

Dimensions

unit: inch

DN	2"	2-1/2"	3"	4"	5"	6"
L	6"	7"	7-1/2"	9"	10"	10-1/2"
H	11"	12"	13-2/5"	15"	18"	19"
C	7"	7"	8"	10"	10"	12"
D	3-1/2"	4-3/10"	4-4/5"	5-7/10"	6-7/10"	7-7/10"
L1	1-4/5"	1-4/5"	2"	2-1/5"	2-3/10"	2-2/5"
G(Rc)	2"	2-1/2"	3"	4"	5"	6"

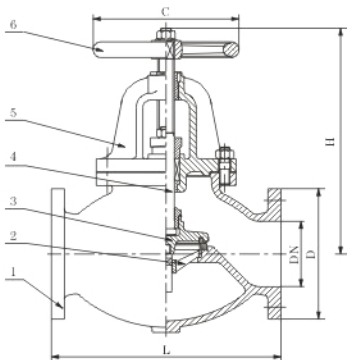
Components

1	Body	Cast iron or ductile iron
2	Seat	Bronze or Brass
3	Disc	Cast iron or ductile iron
4	Stem	Brass or stainless
5	Bonnet	Cast iron
6	Hand wheel	Cast iron or ductile iron

Application

1	Face to face is according to ANSI B16.10
2	Flange drilled is according to ANSI B16.1
3	Nominal pressure 125PSI

Test

Working pressure	125PSI
	150PSI
Test pressure Shell	300PSI
Seat	200PSI

Dimensions

unit: inch

DN	2"	2-1/2"	3"	4"	5"	6"	8"	10"	12"
L	8"	8-1/2"	9-1/2"	11-1/2"	13"	14"	19-1/2"	24-1/2"	27-1/2"
H	10-3/4"	11-3/4"	12-1/4"	13-7/8"	14-3/4"	16-3/4"	20-1/4"	24-1/2"	30"
D	6"	7"	7-1/2"	9"	10"	11"	13-1/2"	16"	19"
C	7"	7"	8"	10"	10"	12"	14"	16"	18"

Strainers ANSI Class 125/150

RSV NO.19 (A)

Components

1	Body	Cast iron or Ductile iron
2	Plug	Cast iron or Ductile iron
3	Cover	Cast iron or Ductile iron
4	Screen	stainless steel
5	Bolt	Carbon steel

Application

1	Face to face is according to ANSI 125/150
2	Flange drilled is according to ANSIB16.1/B16.5
3	Class125 Flat face flange
4	Class150 Raised face flange

Test

Working pressure	125PSI	150PSI
Shell pressure	300PSI	
Seat pressure	200PSI	

Dimensions

unit: mm

DN	50	65	80	100	125	150	200	250	300
L	225.4	273	292	352.4	420	470	543	660.4	762
H	120	140	170	220	260	300	360	440	525
D	152	178	191	229	254	279	343	406	483

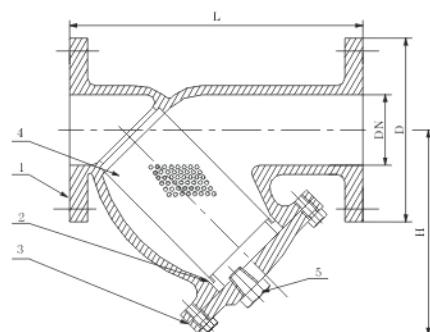

Check valves swing Class 125/150

RSV NO.19 (B)

Components

1	Body	Cast iron or ductile iron
2	Seat	Brass
3	Disc	Cast iron or ductile iron
4	Hanger	Cast iron or ductile iron
5	Ingo pin	stainless steel
6	Bonnet	Cast iron or ductile iron

Application

1	Face to face is according to MSS-SP-71
2	Flange drilled is according to B16.1/B16.5

Test

Working pressure	125PSI	150PSI
Test pressure Shell	300PSI	
Seat	200PSI	

Dimensions

unit: inch

DN	1-1/2"	2"	2-1/2"	3"	4"	5"	6"	8"	10"	12"
L	6-1/2"	8"	8-1/2"	9-1/2"	11-1/2"	13"	14"	19-1/2"	24-1/2"	27-1/2"
H	5"	5-1/8"	5-1/3"	6"	7-1/3"	7-3/4"	9-1/4"	11-1/4"	12"	13-7/8"
D	5"	6"	7"	7-1/2"	9"	10"	11"	13-1/2"	16"	19"

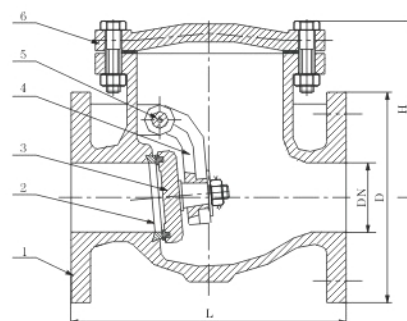

Non-rising stem soft seated gate valves GB-SJKCZ

RSV NO.25 (A)

Components

1	Body	Cast iron or ductile iron
2	Seat	Ductally grade+spray or ss
4	Stem	Stainless steel

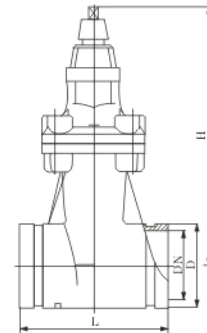

Dimensions

unit: inch

DN	50	65	80	100	150	200	250	300	350	400	450	500	600
L	120	145	155	175	225	275	325	355	380	405	430	455	505
H	230	245	310	345	450	550	620	750	880	1000	1130	1250	1500
C	180	180	200	200	240	320	320	400	500	500	640	640	720
g	57	76	89	114	168	219	273	325	377	426	480	530	630

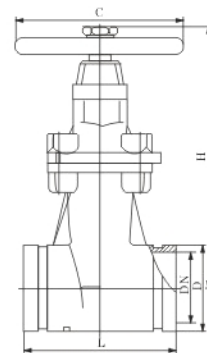

Soft seated gate valves with signal GB-SJKSZ

RSV NO.25 (B)

Components

1	Body	Cast iron or ductile iron
2	Seat	Ductally grade+spray or ss
4	Stem	Stainless steel



Dimensions

unit: inch

DN	50	65	80	100	150	200	250	300	350	400	450	500	600
L	120	145	155	175	225	275	325	355	380	405	430	455	505
H	330	345	410	445	550	650	720	850	980	1100	1250	1400	1650
C	180	180	200	200	240	320	320	400	500	500	640	640	720
g	57	76	89	114	168	219	273	325	377	426	480	530	630

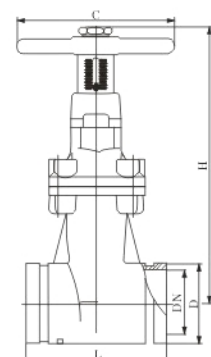

RSV NO.26 (A)

Rising stem soft seated gate valves GB-SJKRZ

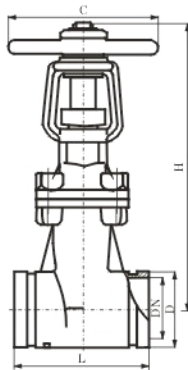

Components

1	Body	Cast iron or ductile iron
2	Seat	Ductally grade+spray or ss
4	Stem	Stainless steel

Dimensions

unit: inch

DN	50	65	80	100	150	200	250	300	350	400	450	500	600
L	120	145	155	175	225	275	325	355	380	405	430	455	505
H	300	320	370	400	620	800	1000	1200	1400	1600	1800	2000	2400
C	180	180	200	200	240	320	320	400	500	500	640	640	720
g	57	76	89	114	168	219	273	325	377	426	480	530	630

RSV NO.26 (B)

Rising stem resilient seated gate valves GB-RRHX

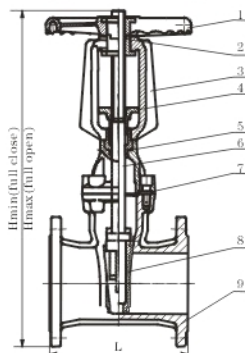

Material

Serial no.	part	material
1	Handwheel	Ductile iron
2	Stem nut	Copper alloy
3	Support	Grey cast iron, ductile cast iron , cast steel
4	Gland	ductile cast iron , cast steel
5	Gasket	Buna-N rubber or EPDM
6	Stem	Stainless steel
7	Gasket	Buna-N rubber or EPDM
8	Disc	Ductile cast iron packed with rubber or EDPM outside
9	Body	Grey cast iron, ductile cast iron , cast steel

Main dimensions

unit: mm

DN	50	65	80	100	125	150	200	250	300	350	400
L	178	190	203	229	254	267	292	330	356	381	406
Hmin (full close)	322	332	350	420	581	581	736	882	1009	1300	1380
Hmax (full open)	374	398	429	524	721	736	942	1013	1117	1655	1805

Special fire signal resilient seated gate valves GB-RRHN

RSV NO.27 (A)

Material

No.	part	material
1	Transmission cap	ductile cast iron , cast steel
2	Handwheel	Ductile iron
3	Dust proof gasket	Plastic
4	Gasket	Buna-N rubber or EPDM
5	Thrust bearing	Gunmetals
6	Cover	Grey cast iron, ductile cast iron , cast steel
7	Bolt	Carbon steel or stainless steel
8	Body	Grey cast iron, ductile cast iron , cast steel
9	Copper nut	Gunmetals
10	Stem	Stainless steel
11	Disc	Ductile cast iron packed with rubber or EPDM outside

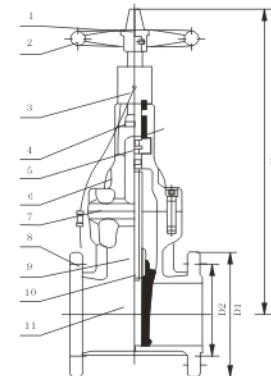

Main dimensions

unit: mm

DN	50	65	80	100	125	150	200	250	300	350	400	450	500	600
L	178	190	203	229	254	267	292	330	356	381	406	432	457	508
H (full open)	732	773	820	870	915	1003	1110	1263	1360	1550	1610	1900	1938	2120

Rising stem resilient gate valves GB-RRHX

RSV NO.27 (B)

Material

Serial no.	Part	Material
1	Handwheel	Ductile iron
2	Stem nut	Copper alloy
3	Support	Grey cast iron, ductile cast iron , cast steel
4	Gland	ductile cast iron , cast steel
5	Gasket	Buna-N rubber or EPDM
6	Stem	Stainless steel
7	Gasket	Buna-N rubber or EDPM
8	Disc	Ductile cast iron packed with rubber or EDPM outside
9	Body	Greycast iron, ductile cast iron , cast steel

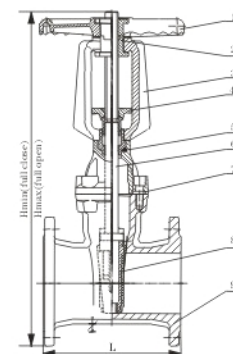

Main dimensions

unit : mm

DN	50	65	80	100	125	150	200	250	300	350	400	450	500	600
L	178	190	203	229	254	267	292	330	356	381	406	432	457	508
Hmin (full close)	313	332	372	424	497	562	680	837	948	1010	1220	1280	1480	1665
Hmax (full open)	355	375	415	476	540	600	720	875	990	1050	1245	1310	1560	1750

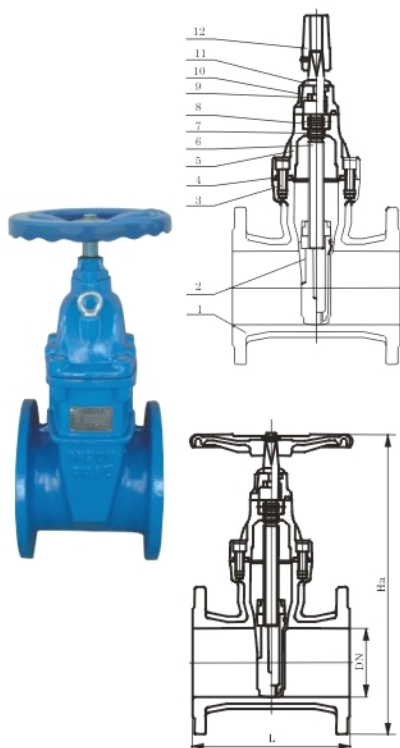
RSV NO.28 (A)
Non-rising stem resilient seated gate valves GB-RVHX, RVCX

Main material

Serial no.	part	material
1	Body	Grey cast iron, ductile cast iron , cast steel
2	Disc	Ductile cast iron packed with rubber or EDPM outside
3	Bolt	Carbonized treatment
4	Gasket	Buna-N rubber or EPDM
5	Cover	Grey cast iron, ductile cast iron , cast steel
6	Stem	tainless steel
7	O-ring	Buna-N rubber or EPDM
8	Thrust bearing	Gunmetals
9	Bolt	Stainless steel
10	Gland	ductile cast iron , cast steel
11	Dust proof gasket	Buna-N rubber
12	Handwheel(transmission cap)	Cast iron

Main dimensions

unit: mm

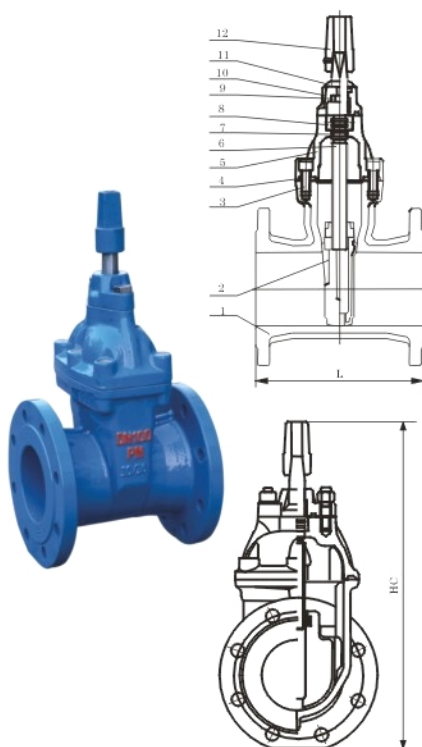
DN	50	65	80	100	125	150	200	250	300	350	400	450	500	600
L	178	190	203	229	254	267	292	330	356	381	406	432	457	508
Hmin (full close)	313	332	372	424	497	562	680	837	948	1010	1220	1280	1480	1665
Hmax (full open)	355	375	415	476	540	600	720	875	990	1050	1245	1310	1560	1750

RSV NO.28 (B)
Non-rising stem resilient seated gate valves GB-RVHX, RVCX

Material

Serial no.	part	material
1	Body	Grey cast iron, ductile cast iron , cast steel
2	Disc	Ductile cast iron packed with rubber or EDPM outside
3	Bolt	Carbonized treatment
4	Gasket	Buna-N rubber or EPDM
5	Cover	Grey cast iron, ductile cast iron , cast steel
6	Stem	tainless steel
7	O-ring	Buna-N rubber or EPDM
8	Thrust bearing	Gunmetals
9	Bolt	Stainless steel
10	Gland	ductile cast iron , cast steel
11	Dust proof gasket	Buna-N rubber
12	Handwheel(transmission cap)	Cast iron

Main dimensions

unit: mm

DN	50	65	80	100	125	150	200	250	300	350	400	450	500	600
L	178	190	203	229	254	267	292	330	356	381	406	432	457	508
Hmin (full close)	313	332	372	424	497	562	680	837	948	1010	1220	1280	1480	1665
Hmax (full open)	355	375	415	476	540	600	720	875	990	1050	1245	1310	1560	1750

Electric resilient seated gate valves GB-RVEX

RSV NO.29 (A)

Material

Serial no.	Part	Material
1	Body	Grey cast iron, ductile cast iron , cast steel
2	Disc	Ductile cast iron packed with rubber or EPDM outside
3	Stem	Stainless steel
4	Cover	Grey cast iron, ductile cast iron , cast steel
5	Support	Grey cast iron, ductile cast iron , cast steel
6	Electric actuator	

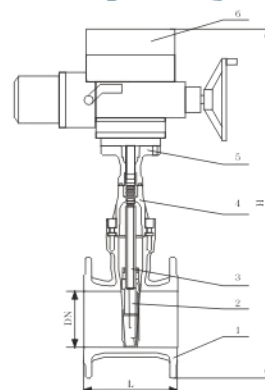

Main dimensions

unit : mm

DN	50	65	80	100	125	150	200	250	300	350	400	450	500	600
L	178	190	203	229	254	267	292	330	356	381	406	432	457	508
H (full open)	732	773	820	870	915	1003	1110	1263	1360	1550	1610	1900	1938	2120

Gear resilient seated gate valves

RSV NO.29 (B)

Material

No.	part	material
1	Body	Grey cast iron, ductile cast iron , cast steel
2	Disc	Ductile cast iron packed with rubber or EDPM outside
3	Bolt	Carbonized treatment
4	Gasket	Buna-N rubber or EPDM
5	Cover	Grey cast iron, ductile cast iron , cast steel
6	Stem	Stainless steel
7	O-ring	Buna-N rubber
8	Thrust bearing	Gunmetals
9	Bolt	Carbon steel or alloy
10	Gland	ductile cast iron , cast steel
11	Dust proof gasket	Buna-N rubber
12	Handwheel	Ductile iron

Main dimensions

unit : mm

DN	500	600	700	800	900	1000	1200
L	457	508	660	720	780	840	960
Hmin (full close)	1480	1665	2200	2800	2800	3000	3000
Hmax (full open)	1650	1900	2350	2950	2950	3150	3150
H (ELECTRIC)	the electric actuator according to the client's requirement						

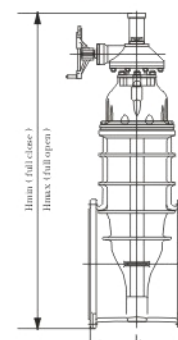

Check valves flanged end swing type, resilient seated

RSVNO.31 (A)

Components

Body	Cast iron/ductile iron
Bonnet	Cast iron/ductile iron
Disc	Cast iron/ductile iron with NBR or EPDM
Hinge pin	Stainless steel



Application

Face to face is according to BS5153/MSS-SP-71.

Flange drilled is according to BS4504/ANSI B16.1/B16.5

Test

Working pressure	PN16	125/150 PSI
Shell pressure	PN24	300 PSI
Seat pressure	PN17.6	200 PSI

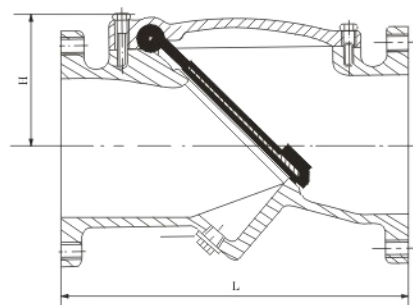

Dimensions

unit:mm

Size(DN)	50	65	80	100	125	150	200	250	300	350	400	450	500	600
L	203	216	241	292	330	356	496	622	699	787	912	965	1067	1210
H	86	90	98	117	130	149	194	251	310	360	420	480	520	570
Art No.GVCDI-018(A):PN16-BS5153														
Dia.of flange	165	185	200	220	250	285	340	405	460	520	580	640	715	840
Nos.of hole	4	4	8	8	8	8	12	12	12	16	16	20	20	20
Dia.of hole	18	18	18	18	18	22	22	20	20	20	30	30	34	36
P.C.D	125	145	160	180	210	240	295	355	410	470	525	585	650	770
ANSI Class 125/Class 150														
Dia.of flange	152	178	191	229	254	279	343	406	483	533	597	635	699	813
Nos.of hole	4	4	4	8	8	8	8	12	12	12	16	16	20	20
Dia.of hole	19	19	19	19	22	22	22	25	25	25	29	32	32	35
P.C.D	121	139	152	191	216	241	298	362	432	476	540	578	635	749

RSV NO.32 (A)

Check valves wafer type

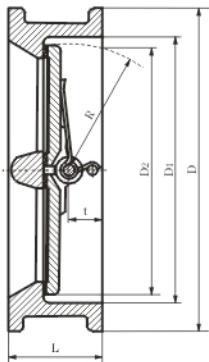

Components

Body	Cast iron or Ductile iron
Disc	Ductile iron with zinc plated or Al-bronze/stainless steel
Stem	Stainless steel
Spring	Stainless steel
Rubber gasket	NBR/EPDM

Application

Face to face is according to ISO Standard
Flange drilled is according to DIN/BS/JIS/ANSI

Test

Working pressure	PN10/PN16	CLASS125/150
Shell pressure	PN15/PN24	300PSI
Seat pressure	PN11/PN17.6	200PSI

Dimensions

Size(DN)	50	65	80	100	125	200	250	300	350	400	450	500	600	700	800
L	43	46	64	64	70	76	89	114	114	127	140	152	152	178	229
D1	65	80	94	117	145	170	224	265	310	360	410	450	505	624	720
D2	43	60	66	91	117	145	198	234	284	333	381	420	468	573	680
t	19	20	23	27	30	31	33	40	43	45	52	58	5/8	73	98
R	29	36	43	53	66	79	104	127	148	172	197	218	241	295	354

Remark:The design of dimension "D" can be suitable for all standard (BS, DIN, ANSI, JIS standard etc.)

RSV NO.32 (B)

Check valves silent type

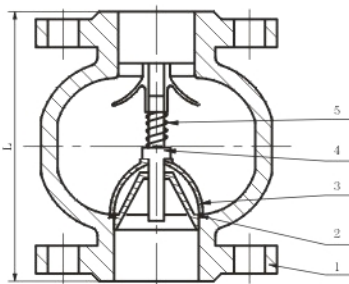

Components

1	Body	Cast iron or Ductile iron
2	Disc ring	NBR
3	Disc	Cast iron or Ductile iron
4	Stem	stainless steel
5	Spring	stainless steel

Application

1	Face to face is according to ISO standard
2	Flange drilled is according to ANSI\BS\DIN\JIS

Test

Working pressure	PN10/PN16	125PSI/150PSI
Shell pressure	PN15/PN24	200PSI
Seat pressure	PN11/PN17.6	300PSI

Dimensions

DN	50	65	80	100	125	150	200	250	300
L	120	120	140	170	200	220	288	344	385

Foot valves, flanged end

RSV NO.33 (A)

Components

Body	Cast iron/ductile iron
Disc	Cast iron/ductile iron
Disc ring	NBR
Spring	Stainless steel/steel with zinc
Screen	Stainless steel/steel zinc plated

Application

Face to face is according to ISO STANDARD
Flange drilled is according to DIN,BS,JIS,ANSI etc.

Test

Working pressure	PN10/PN16	Class 125/150
Shell pressure	PN11/PN17.6	200 PSI
Seat pressure	PN15/PN24	300 PSI

Dimensions

Size(DN)	50	65	80	100	125	150	200	250	300
L	120	120	140	170	200	220	288	344	385

unit:mm

Remark: Our design can be suitable for all standard (BS,DIN,ANSI, JIS standard etc.).

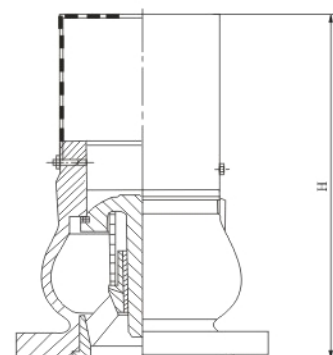

Ball valves ANSI 125/150

RSV NO.33 (B)

Components

1	Body	Cast iron or ductile iron
2	Ball	Stainless steel
3	Ball seat	Ptfe
4	Stem	Stainless steel

Test

Working pressure	125PSI	150PSI
Shell pressure	300PSI	
Seat	200PSI	

Dimensions

DN	50	65	80	100	125	150	200	250
L	178	190	203	229	356	394	457	533
D	152	178	190	229	254	279	343	406
H	120	153	162	191	211	290	340	460

unit:mm

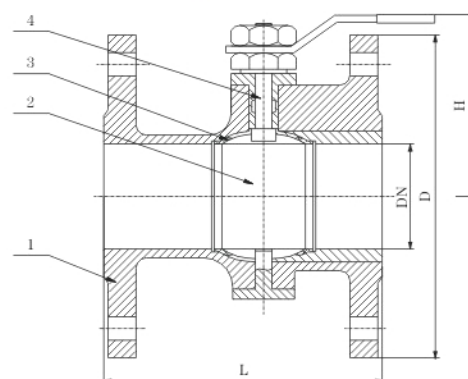

Material

Item No.	Description	Material acc to DIN/UNI	Material comparable to BS
1	Body	GG25 or GGG50	1452:1956 or 2789:61
2	Disc	GGG50	2789:61
3	Retaining ring	GGG50	2789:61
4	Sealing O ring	NBR or EPDM	NBR or EPDM
5	Bush	Cu Sn 10 Zn	1400:61
6	Stop ring	Cu Sn 10 Zn	1400:61
7	Rear cover	GG25 or GGG50	1452:1956 or 2789:61
8	Rear shaft	X15 Cr13	420 S29
9	Drive shaft	X15 Cr13	420 S29
10	Cover	GG25 or GGG50	1542:1961 or 2789:61
11	Taper pin	X15 Cr13	420 S29
12	All screw	Rst 37-2	970:1955 EN3
13	O ring	Perbunan	Perbunan
14	Feather key	Rst 37-2	970:1955 EN3
15	Body seat ring	X15 Cr13	420 S29

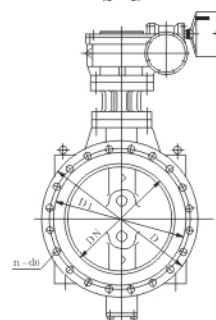
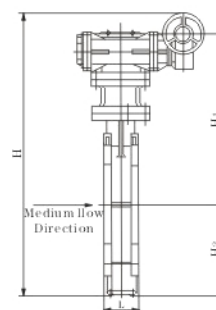

Test

Working pressure	PN10	PN16
Sealing test pressure	PN11	PN17.6
Body test pressure	PN15	PN24
Working temperature	-10 ~ 120°C	
Suitable mediums	Water, sewage, air etc.	

Dimension

Unit: mm

DN	L	H	H ₁	H ₂	φ	PN10			PN16			Wt. (Kg)
						D	D ₁	n-d ₀	D	D ₁	n-d ₀	
100	190	446	234	122	180	220	180	4-18	220	180	8-18	25
150	210	521	279	153	180	285	240	8-22	285	240	8-22	37
200	230	690	349	216	250	340	295	8-22	340	295	12-22	63
250	250	800	406	219	350	395	350	12-22	405	355	12-26	94
300	270	959	542	267	300	445	400	12-22	460	410	12-26	148
350	290	1048	583	315	300	505	460	16-22	520	470	16-26	188
400	310	1120	620	350	300	565	515	16-26	580	525	16-30	237
450	330	1190	667	373	300	615	565	20-26	640	585	20-30	268
500	350	1280	702	428	300	670	620	20-26	715	650	20-34	289
600	390	1409	759	450	400	780	725	20-30	840	770	20-36	480
700	430	1613	885	528	400	895	840	24-30	910	840	24-36	615
800	470	1736	1013	573	300	1015	950	24-33	1025	950	24-39	818
900	510	1860	1071	639	300	1115	1050	28-33	1125	1050	28-39	956
1000	550	2107	1234	723	300	1230	1160	28-36	1255	1170	28-42	1277
1200	630	2326	1343	833	300	1455	1380	32-39				1764

Deisgn can be suitable for bs5155 PN10/PN16, din 10, din pn16, uni PN10, uni PN16.

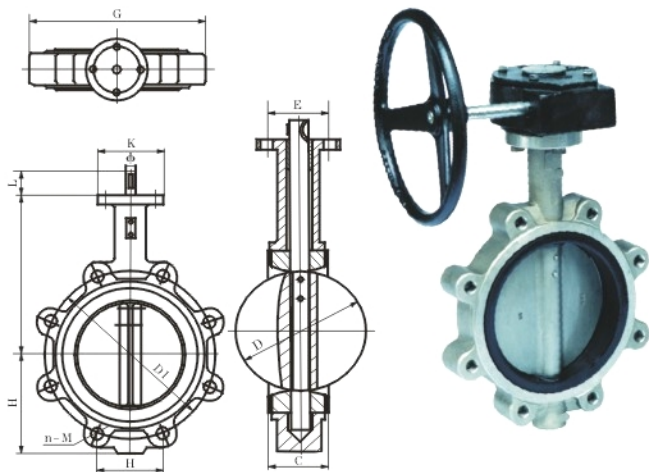
Butterfly valves lug type

Components

1	Body	Castiron / Ductileiron
2	Disc	Ductile iron with nickel plated, Bronze, Stainless steel SS304 and SS316
3	Stem	Stainless steel
4	Seat	NBR, EPDM, VITON, PTFE
5	O ring	NBR

Application

1	The design can be suitable for BS/ANSI/DIN/UNI/JIS standard etc.
2	For water, neutral liquids, oil and Air etc.
3	Coating epoxy painting, 150 um.

Test

Working Pressure	PN6/PN10/PN16/125Psi/150Psi	
Test pressure	Shell	1.5 x Working pressure
	Seat	1.1 x Working pressure

Dimension

Unit: mm

DN	A	B	C	D	L	D ₁	n-M	K	E	Φ	G
50	161	80	42	52.9	32	This dimension can be acc to BS5155, ANSI CL125, ANSI CL150, DIN PN6, DIN PN10, DIN PN16, JIS, UNI Standard ect	This dimension can be acc to BS5155, ANSI CL125, ANSI CL150, DIN PN6, DIN PN10, DIN PN16, JIS, UNI Standard ect	77	57.2	12.6	118
65	175	89	44.7	64.5	32			77	57.2	12.6	137
80	181	95	45.2	78.8	32			77	57.2	12.6	178
100	200	114	52.1	104	32			92	69.9	15.7	206
125	213	127	54.4	123.3	32			92	69.9	18.9	238
150	226	139	55.8	155.6	32			92	69.9	18.9	266
200	260	275	60.6	202.5	45			115	88.9	22.1	329
250	292	203	65.6	250.5	45			115	88.9	28.5	393
300	337	242	76.9	301.6	45			140	108	31.6	462
350	368	267	76.5	333.3	45			140	108	31.6	515
400	400	309	86.5	389.6	51.2			197	159	33.2	579
450	422	328	105.6	440.5	51.2			197	159	38	627
500	480	361	131.8	491.6	64.2			197	159	41.2	696
600	562	459	152	592.5	70.2			276	216	50.7	821
700	624	520	163	695	82	300	254	63	895		

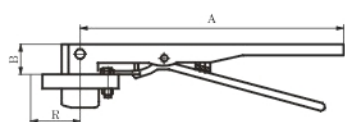
Overall dimensions & weight of manual actuator

Size mm (in.)	A	B	R	Weight (Kg)
50(2)-100(4)	266.7	32	52	0.80
125(5)-150(6)	313	32	52	1
200(8)-250(10)	359	45	75.2	2.0
300(12)	490	45	75.2	3.0

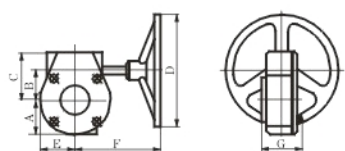
Overall dimensions & weight of wormgear actuator

Model	Size mm (in.)	A	B	C	E	F	G	D	Weight(Kg)
3DB-15	50(2)-150(6)	52	45	74	52	152.5	75	150	4.8
3DB-50	200(8)-250(10)	75	62.75	101	75	250	86	300	11.7
3DB-120	300(12)-350(14)	81	80	118	81	227	83	300	14

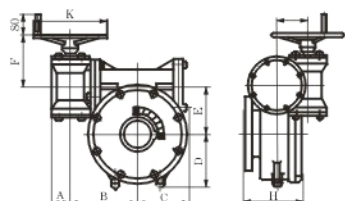
Overall dimensions & weight of double-stage wormgear actuator

Model	Size mm (in.)	A	B	C	D	E	F	H	L	K	Weight(Kg)
3D-30/250	400(16)-450(18)	42	160	125	130	90	200	105	60	300	40
3D-30/300	500(20)	42	185	160	150	110	200	120	60	380	55
3D-30/400	600(24)	42	185	160	170	125	225	120	60	380	60
3D-60/800	700(28)-800(32)	50	228	185	190	155	155	125	78	380	90
3D-120/1500	900(36)-1000(40)	65	266	200	230	192	192	200	120	450	160

Components

1	Body	Cast iron / Ductile iron
2	Disc	Ductile iron with nickel plated, Bronze, Stainless steel SS304 and SS316 etc.
3	Stem	Stainless steel
4	Seat	NBR, EPDM, VITON, PTFE etc.
5	O ring	NBR

Application

1	The design can be suitable for BS/DIN/ANSI/JIS/UNI standard etc.
2	For water, neutral liquids, oil and Air etc.
3	Coating epoxy painting, 150 um.

Test

Working Pressure	PN6/PN10/PN16/125Psi/150Psi	
Test pressure	Shell	1.5 x Working pressure
	Seat	1.1 x Working pressure

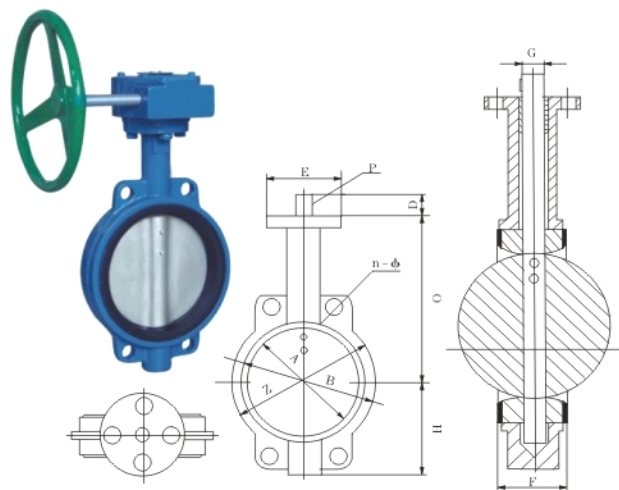

Unit: mm

Dimension

DN	A	B	C	D	E	F	G	H	Z	P	4-φ
50	53	This dimension can be acc to BS5155, ANSI CL125, ANSI CL150, DIN PN6, DIN PN10, DIN PN16, JIS, UNI Standard ect.	145	32	77	42	12.7	80	100	3	This dimension can be acc to BS5155, ANSI CL125, ANSI CL150, DIN PN6, DIN PN10, DIN PN16, JIS, UNI Standard ect.
65	65		160	32	77	45	12.7	89	120	3	
80	78.9		165	32	77	45	12.7	95	127	3	
100	104.5		185	32	92	52	15.9	114	156	5	
125	123.5		200	32	92	54	19.0	127	190	5	
150	156		210	32	92	56	19.0	139	212	5	
200	203		245	45	115	60	22.3	175	268	5	
250	251		285	45	115	66	28.6	203	325	8	
300	301.8		325	45	140	77	31.8	242	403	8	
350	333.3		368	45	140	77	31.8	267	436	8	
400	389.6		400	51.2	197	87	33.2	309	488	8	
450	440.51		422	51.2	197	106	38	328	540	9.5	
500	491.6		480	64.2	197	132	41.2	361	595	9.5	
600	592.5		562	70.2	276	152	50.7	459	695	13	
700	695		624	66	300	163	55	520			
800	794.7		672	66	300	188	55	591			
900	864.7	720	118	300	203	75	656				
1000	965	800	142	300	216	85	721				

Overall dimensions & weight of manual actuator

Size mm (in.)	A	B	R	Weight (Kg)
50(2)-100(4)	266.7	32	52	0.80
125(5)-150(6)	313	32	52	1
200(8)-250(10)	359	45	75.2	2.0
300(12)	490	45	75.2	3.0

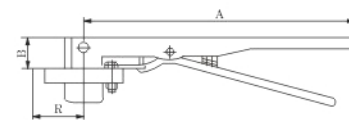

Overall dimensions & weight of wormgear actuator

Model	Size mm (in.)	A	B	C	E	F	G	D	Weight(Kg)
3DB-15	50(2)-150(6)	52	45	74	52	152.5	75	150	4.8
3DB-50	200(8)-250(10)	75	62.75	101	75	250	86	300	11.7
3DB-120	300(12)-350(14)	81	80	118	81	227	83	300	14

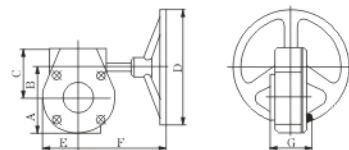

Overall dimensions & weight of double-stage wormgear actuator

Model	Size mm(in.)	A	B	C	D	E	F	H	L	K	Weight(Kg)
3D-30/250	400(16)-450(18)	42	160	125	130	90	200	105	60	300	40
3D-30/300	500(20)	42	185	160	150	110	200	120	60	380	55
3D-30/400	600(24)	42	185	160	170	125	225	120	60	380	60
3D-60/800	700(28)-800(32)	50	228	185	190	155	155	125	78	380	90
3D-120/1500	900(36)-1000(40)	65	266	200	230	192	192	200	120	450	160

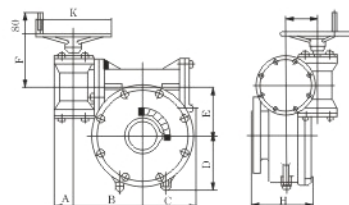

Floating flange rubber expansion joints

RSV NO.72

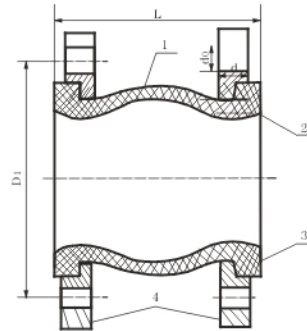

Technical condition

Item	Type	JGD-1	JGD-2	JGD-3
MPa(kg.f/cm ²) Working pressure		1(10)	1.6(16)	2.5(25)
MPa(kg.f/cm ²) Bursting pressure		2(20)	3(30)	4.5(45)
Vacuity KPa(mmHg)		53.3(400)	86.7(650)	100(750)
Applicable temperature °C		-15~+115, Mannerism -30~+250		
Applicable medium		Air, Compresses air, water, sea water, hot water, acid, etc.		

Application

1	Body
2	Lining
3	Shell Sheet
4	Flange

Table of main parameters of nominal core diameter, length, displacement and flange

DN Nominal diameter		L Length (mm)	Flange thickness (mm)	No. of bolt n	Diameter of bolt hole d ₀ (mm)	Diameter of bolt hole center circle D1(mm)	Axial displacement (mm)		Lateral displacement (mm)	Angle of deflection (α ₁ +α ₂)
(mm)	(in)						Stretch	Compression		
32	1 1/4	95	16	4	18	100	6	9	9	15°
40	1 1/2	95	18	4	18	110	6	10	9	15°
50	2	105	18	4	18	125	7	10	10	15°
65	2 1/2	115	20	4	18	145	7	13	11	15°
80	3	135	20	8	18	160	8	15	12	15°
100	4	150	22	8	18	180	10	19	13	15°
125	5	165	24	8	18	210	12	19	13	15°
150	6	180	24	8	22	240	12	20	14	15°
200	8	210	24	8	22	295	16	25	22	15°
250	10	230	28	12	22	350	16	25	22	15°
300	12	245	28	12	22	400	16	25	22	15°
350	14	255	28	16	22	460	16	25	22	15°
400	16	255	30	16	26	515	16	25	22	15°
450	18	255	30	20	26	565	16	25	22	15°
500	20	255	32	20	26	620	16	25	22	15°
600	24	260	36	20	26	725	16	25	22	15°
700	28	320	36	24	30	840	16	25	22	15°
800	32	340	36	24	30	950	16	25	22	15°
900	36	370	36	24	30	1050	16	25	22	15°
1000	40	400	36	28	30	1160	18	26	24	15°
1200	48	420	36	32	33	1380	18	26	24	15°

Note: 1. DN32-1200PN=1MPa 2. DN32-300PN=1.6MPa 3. DN32-300PN=2.5MPa 4. Flange selected according to JB81-59.

5. Special requirements may be satisfied to order by correspondence and graph.

6. When using this product for high water supply, the pipeline should be provided with fixed support or bracket, otherwise the product must be fitted with an anti-fall device. The force of fixed support or bracket should be greater than axial force, otherwise an anti-fall device is also needed.

Floating flange double spherical rubber expansion joints

RSV NO.73

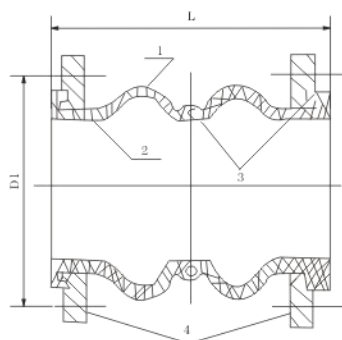

Technical condition

Item	Type	200-300(8-12")		50-150(2-6")
		JGD-A(1)	JGD-A(2)	JGD-A(3)
MPa(kg.f/cm ²) Working pressure		1(10)	1.6(16)	2.5(25)
MPa(kg.f/cm ²) Bursting pressure		2(20)	3(30)	4.5(45)
Vacuity KPa(mmHg)		400(300)	53.3(400)	86.7(650)
Applicable temperature °C		-15~+115, Mannerism-30~+250		
Applicable medium		Air.Compressed air, water, sea water, hot water, acid, etc.		

Table of main parameters of nominal core diameter,length displacement viue and flange

DN Nominal diameter		L Length (mm)	Flange thicknessb (mm)	No.of bolt n	Diameter of bolt hole d ₀ (mm)	Diameter of bolt hole center circle D ₁ (mm)	Axial displacement (mm)		Lateral displacement (mm)	Angle of deflection (α ₁ +α ₂)
(mm)	(in)						Stretch	Compression		
50	2	165	18	4	17.5	125	30	50	45	35°
65	2½	175	20	4	17.5	145	30	50	45	35°
80	3	175	20	8	17.5	160	35	50	45	35°
100	4	225	22	8	17.5	180	35	50	40	35°
125	5	225	24	8	17.5	210	35	50	40	35°
150	6	225	24	8	22	240	35	50	40	35°
200	8	325	24	8	22	295	35	50	40	35°
250	10	325	28	12	22	350	35	60	35	30°
300	12	325	28	12	22	400	35	60	35	30°

Note: Special requirements may be satisfied to order by correspondence and graph.

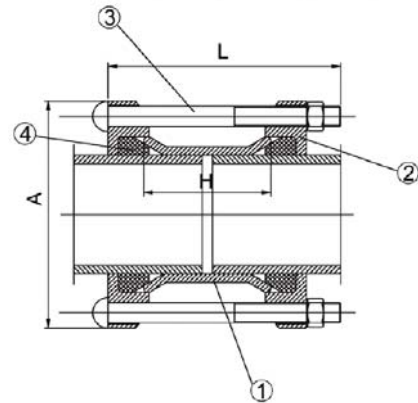

- Suitable for water and neutral liquids (sewage).
- Working temperature up to 70°C.
- Test conform to EN 12266.
- Flanges and drilling acc. to EN 1092-2.
- Fully corrosion resistant constructions.
- Inside and outside fusion bonded epoxy coatings.
- EPDM gaskets.
- vibration absorption, end movements and angular deflection +/-8 degree.

No.	Reference	Material	Standard
1	Sleeve	Steel / Ductile Iron	
2	End Ring	GJS-400-15	EN 1563
3	Bolt & Nut	Steel 8.8 Zinced	
4	Gasket	EPDM/NBR	EN 681

PIPE	RANGE	BOLT	A	H	WEIGHT	
Norm	L	QTY	MM	MM	KGS	
DN50	59-72	M12x180	2	165	98	3.00
DN65	72-85	M12x180	2	185	98	4.00
DN80	88-103	M12x180	4	185	98	4.10
DN100	109-128	M12x180	4	208	98	4.80
DN125	132-146	M12x200	4	250	98	6.30
DN150	159-182	M12x200	4	272	98	7.20
DN175	192-210	M12x220	4	312	135	12.00
DN200	218-235	M12x220	4	335	135	12.50
DN250	272-289	M12x220	6	405	135	19.00
DN300	315-332	M12x220	8	460	135	22.00
DN300	322-339	M12x200	6	435	102	20.40
DN300	340-360	M12x240	6	455	102	22.00
DN300	357-368	M12x240	8	510	130	31.90
DN350	374-391	M16x240	8	510	130	33.00
DN400	400-429	M16x240	8	489	130	38.50
DN450	418-435	M16x240	8	580	130	39.60
DN400	425-442	M16x240	8	580	130	40.70
DN450	455-472	M16x240	10	715	130	45.10
DN450	476-493	M16x240	10	640	130	47.30
DN500	527-544	M16x240	10	690	130	53.90
DN500	555-572	M16x240	10	715	130	55.00
DN500	566-583	M16x240	10	715	130	55.00
DN500	582-599	M16x240	10	715	130	57.20
DN600	600-630	M16x260	10	790	130	71.50
DN600	662-679	M16x260	10	840	130	77.00

Flange Adaptor for PVC, PE & DI Pipes — PN10/16

- Suitable for water and neutral liquids (sewage).
- Working temperature up to 70°C.
- Test conform to EN 12266.
- Flanges and drilling acc. to EN 1092-2.
- Fully corrosion resistant constructions.
- Inside and outside fusion bonded epoxy coatings.
- EPDM gaskets.

DN	Pipe OD		OD TOL		A	B	C	D	Bolts	
mm	mm	inch	mm	PN	mm	mm	mm	mm	Qty	Size
80	98	3,86	+2.1-2.6	10	19	73	108	200	4	M12x100
100	118	4,65	+2.1-3.0	10	19	76	115	220	4	M12x110
125	144	5,67	+2.3-3.0	10	19	76	115	250	4	M12x110
150	170	6,96	+2.3-3.0	10	19	76	115	285	4	M12x110
200	222	8,74	+2.4-3.5	10	20	76	115	340	4	M12x110
250	274	10,79	+2.5-3.5	10	22	90	127	400	6	M12x120
300	326	12,83	+2.6-3.5	10	22	90	127	455	6	M12x120
350	378	14,88	+2.7-3.5	10	25	108	152	505	8	M16x145
400	429	16,89	+2.8-4.0	10	25	108	152	565	8	M16x145
450	480	18,89	+2.9-4.0	10	25	108	152	615	10	M16x145
500	532	20,94	+3.0-4.0	10	26	114	160	670	10	M16x150
600	635	25,00	+3.2-4.0	10	26	114	160	780	10	M16x150
700	738	29,05	+3.4-4.5	10	26	114	160	895	12	M16x150
800	842	33,15	+1.0-4.5	10	26	114	160	1015	12	M16x150
900	945	37,20	+1.0-5.0	10	26	114	160	1115	14	M16x150
1000	1048	41,25	+1.0-5.0	10	26	114	160	1230	14	M16x150
1100	1152	45,35	+1.0-6.0	10	40	127	178	1340	16	M16x165
1200	1255	49,41	+1.0-6.0	10	40	127	178	1435	16	M16x165
1400	1462	57,66	+1.0-7.0	10	40	127	178	1675	18	M16x165
1600	1668	65,67	+1.0-7.0	10	60	190	275	1915	40	M16x235
1800	1875	73,82	+1.0-7.0	10	60	190	275	2115	44	M16x235
2000	2082	81,97	+1.0-8.0	10	60	190	275	2325	48	M16x235
80	98	3,86	+2.1-2.6	16	19	73	108	200	4	M12x100
100	118	4,65	+2.1-3.0	16	19	76	115	220	4	M12x110
125	144	5,67	+2.3-3.0	16	19	76	115	250	4	M12x110
150	170	6,96	+2.3-3.0	16	19	76	115	285	4	M12x110
200	222	8,74	+2.4-3.5	16	20	76	115	340	4	M12x110
250	274	10,79	+2.5-3.5	16	22	90	127	400	6	M12x120
300	326	12,83	+2.6-3.5	16	22	90	127	455	6	M12x120
350	378	14,88	+2.7-3.5	16	25	108	152	520	8	M16x145
400	429	16,89	+2.8-4.0	16	25	108	152	580	8	M16x145
450	480	18,89	+2.9-4.0	16	25	108	152	640	10	M16x145
500	532	20,94	+3.0-4.0	16	26	114	160	715	10	M16x150

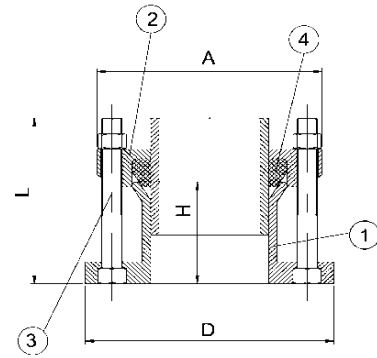

- Suitable for water and neutral liquids (sewage).
- Working temperature up to 70°C.
- Test conform to EN 12266.
- Flanges and drilling acc. to EN 1092-2.
- Fully corrosion resistant constructions.
- Inside and outside fusion bonded epoxy coatings.
- EPDM gaskets.

No.	Reference	Material	Standard
1	Body	GJS-400-15	
2	End Ring	GJS-400-15	EN 1563
3	Bolt & Nut	Steel 8.8 Zincd	
4	Gasket	EPDM/NBR	EN 681

PIPE	RANGE	BOLT		A	D	H	WEIGHT
Norm		L	QITY	MM	MM	MM	KGS
DN50	59-72	125	2	165	165	78	3.5
DN65	72-85	125	2	185	190	78	3.9
DN80	88-103	125	4	185	216	78	4.5
DN100	109-128	125	4	218	225	78	6.0
DN125	132-146	125	4	250	288	78	7.0
DN150	159-182	125	4	272	288	78	7.8
DN175	192-210	130	4	312	345	78	11.6
DN200	218-235	130	4	335	345	78	12.0
DN250	272-289	130	6	405	455	85	14.5
DN300	315-332	130	6	460	455	85	18.5
DN350	374-391	150	8	510	520	108	41.5
DN400	400-429	160	8	489	580	108	49.5
DN400	418-435	160	8	580	580	108	51.2
DN400	425-442	160	8	580	580	108	52.8
DN450	455-472	160	10	620	640	108	57.2
DN500	500-532	180	10	683	715	114	67.1
DN500	527-544	180	10	690	715	114	68.2
DN500	555-572	180	10	715	715	114	69.5
DN500	566-583	200	10	715	715	150	70.5
DN500	582-599	200	10	715	715	150	71.5
DN600	600-630	180	10	790	840	114	82.5
DN600	630-647	180	10	820	840	114	84.7
DN600	645-662	180	10	830	840	114	85.8
DN600	662-679	200	10	840	840	150	86.9
DN600	675-692	200	10	840	840	150	90.2

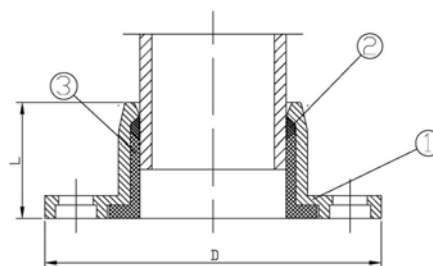
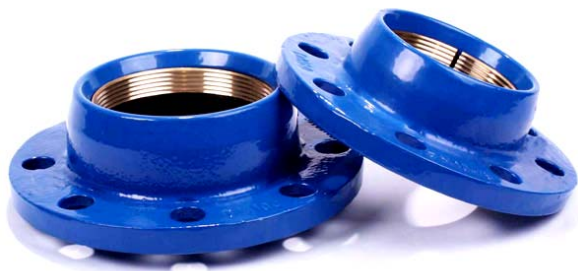

- Suitable for water and neutral liquids (sewage).
- Working temperature up to 70°C.
- Test conform to EN 12266.
- Flanges and drilling acc. to EN 1092-2.
- Fully corrosion resistant constructions.
- Inside and outside fusion bonded epoxy coatings.
- EPDM gaskets.
- Angular deflection +/-3 degree:

No.	Reference	Material	Standard
1	Body	Ductile Iron	EN 1563
2	Ring	Brass	
3	Rubber	EPDM NBR	EN 681 EN 682

PN 10 / PN 16					
SIZE	PIPE OD	L	D	Weight (Kg)	
DN 50	63	55	183	2,23	
DN 60/65	75	58	183	2,56	
DN 80	90	60	200	3,26	
DN 100	110	68	220	4,10	
DN 125	125	70	250	4,80	
DN 125	140	75	250	4,75	
DN 150	160	80	283	6,45	
DN 200	200	93	340	7,50	
DN 250	250	75	340	13,50	
DN 300	315	100	455	14,00	

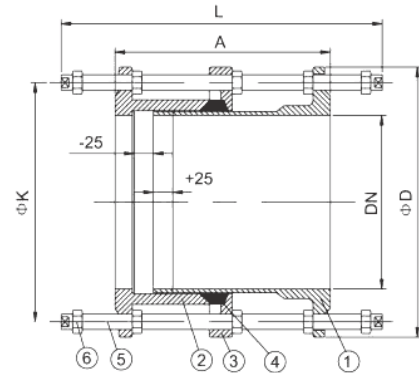

- Suitable for water and neutral liquids (sewage).
- Working temperature up to 70°C.
- Test conform to EN 12266.
- Flanges and drilling acc. to EN 1092-2.
- Fully corrosion resistant constructions.
- Inside and outside fusion bonded epoxy coatings.
- EPDM gaskets.

No.	Reference	Material	Standard
1	Long Piece	GJS-400-15	EN 1563
2	Short Piece	GJS-400-15	EN 1563
3	Flange	GJS-400-15	EN 1563
4	Gasket	EPDM NBR	EN 681 EN 682
5	Stud	Steel zinced	
6	Nut	Steel zinced	

PN10					PN16				
DN	A	D	K	STUD	DN	A	D	K	STUD
80	200	200	160	8x16	80	200	200	160	8x16
100	200	220	180	8x16	100	200	220	180	8x16
125	200	250	210	8x16	125	200	250	210	8x16
150	200	285	240	8x16	150	200	285	240	8x20
200	220	340	295	8x20	200	220	340	295	12x20
250	220	400	350	8x20	250	230	400	355	12x24
300	220	455	400	8x20	300	250	455	410	12x24
350	230	505	460	16x20	350	260	520	470	16x24
400	230	565	515	16x20	400	270	580	525	16x27
450	250	615	565	20x24	450	270	640	585	20x27
500	260	670	620	20x24	500	280	715	650	20x30
600	260	780	725	20x27	600	300	840	770	20x33
700	260	895	840	24x27	700	300	910	840	24x33
800	290	1010	950	24x30	800	320	1025	950	24x36
900	290	1115	1050	28x30	900	320	1125	1050	28x36
1000	290	1230	1160	28x33	1000	340	1255	1170	28x39
1200	320	1455	1380	32x36	1200	360	1485	1390	32x45

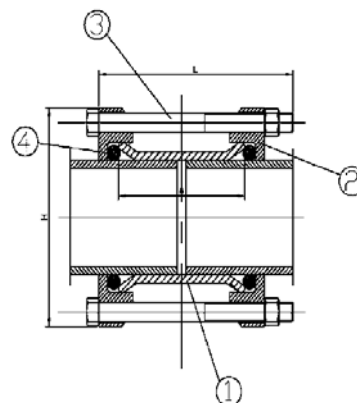

- Suitable for water and neutral liquids (sewage).
- Working temperature up to 70°C.
- Test conform to EN 12266.
- Flanges and drilling acc. to EN 1092-2.
- Fully corrosion resistant constructions.
- Inside and outside fusion bonded epoxy coatings.
- EPDM gaskets.

No.	Reference	Material	Standard
1	Sleeve	Ductile Iron	EN 1563
2	End Ring	Ductile Iron	EN 1563
3	Bolt & Nut	Steel galvanized	
4	O-Ring	EPDM NBR	EN 681 EN 682

SIZE	BOLT		A MM	H MM	WEIGHT KGS
	L	QITY			
DE63	M12x180	2	147	130	1.73
DE75	M12x180	2	149	130	2.16
DE90	M12x180	4	164	130	2.53
DE110	M12x200	4	184	150	3.37
DE125	M12x200	4	199	150	3.76
DE140	M12x200	4	214	150	4.75
DE160	M12x240	4	234	190	6.70
DE180	M12x240	4	254	190	7.64
DE200	M12x240	4	274	190	8.17
DE250	M12x260	6	341	210	14.17
DE315	M12x260	6	406	210	17.47
DE400	M12x260	8	495	210	22.21
DE500	M12x260	10	592	210	27.27

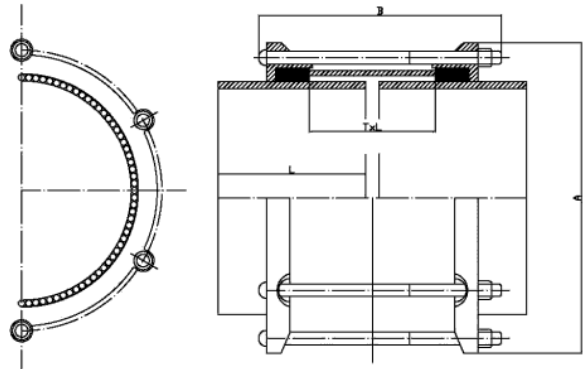

- Suitable for water and neutral liquids (sewage).
- Working temperature up to 70°C.
- Test conform to EN 12266.
- Flanges and drilling acc. to EN 1092-2.
- Fully corrosion resistant constructions.
- Inside and outside fusion bonded epoxy coatings.
- EPDM gaskets.
- vibration absorption, end movements and angular deflection +/-8 degree.

No.	Reference	Material	Standard
1	Sleeve	Steel / Ductile Iron	EN 1563
2	End Ring	GJS-400-15	EN 1563
3	Bolt & Nut	Steel 8.8 Zincd	
4	Gasket	EPDM NBR	EN 681 EN 682

DN	Pipe OD	OD tolerance	A	Sleeve		Bolts		Weight
	mm	mm / mm	mm	Thickness	Length	Qty	Size	kg
80	98	+2.1 -2.6	178	7,00	102	4	M12X160	6,00
100	118	+2.1 -3.0	200	7,20	102	4	M12X160	6,80
125	144	+2.3 -3.0	230	7,50	102	4	M12X160	8,70
150	170	+2.3 -3.0	262	7,80	102	4	M12X165	11,00
200	222	+2.4 -3.5	314	8,40	102	6	M12X165	14,40
250	274	+2.5 -3.5	368	9,00	102	6	M12X165	21,30
300	326	+2.6 -3.5	420	9,60	102	6	M12X165	24,20
350	378	+2.7 -3.5	488	10,20	152	8	M16X240	35,70
400	429	+2.8 -4.0	539	10,80	152	8	M16X240	42,00
450	480	+2.9 -4.0	590	11,40	152	10	M16X240	50,00
500	532	+3.0 -4.0	642	12,00	152	10	M16X240	55,20
600	635	+3.2 -4.0	745	13,20	152	12	M16X240	74,80
700	738	+3.4 -4.5	848	14,40	152	12	M16X240	96,10
800	842	+4.0 -4.5	952	15,60	152	14	M16X240	120,80
900	945	+4.0 -5.0	1060	16,80	278	16	M16X265	142,50
1000	1048	+4.0 -5.0	1163	18,00	278	16	M16X265	165,50
1100	1152	+4.0 -6.0	1280	19,20	290	20	M16X275	195,00
1200	1255	+4.0 -6.0	1383	20,40	290	22	M16X275	248,10
1400	1462	+4.0 -7.0	1590	22,80	290	24	M16X275	326,70
1600	1668	+4.0 -7.0	1798	25,20	290	28	M16X275	375,40
1800	1875	+4.0 -7.0	2015	27,60	295	32	M16X280	696,60
2000	2082	+4.0 -8.0	2222	30,00	295	36	M16X280	790,50

Tapper Saddle — PN10/16

RF 11

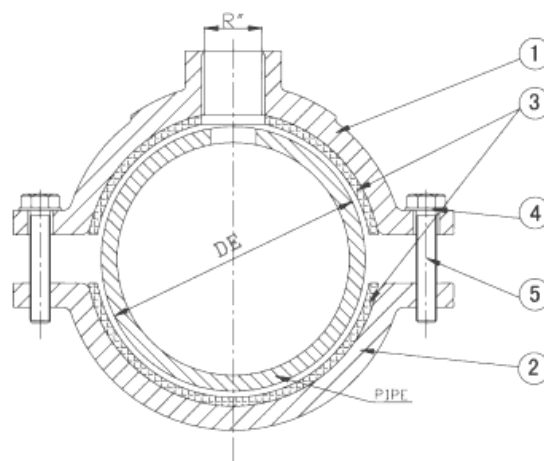

- Suitable for water and neutral liquids (sewage).
- Working temperature up to 70°C.
- Test conform to EN 12266.
- Fully corrosion resistant constructions.
- Inside and outside fusion bonded epoxy coatings.
- Wide outlet range 1/2 to 3".
- Stainless steel fastener.
- EPDM gaskets.

No.	Reference	Material	Standard
1	Body	GJS-400-15	EN 1563
2	Cover	GJS-400-15	EN 1563
3	Gasket	EPDM NBR	EN 681 EN 682
4	Washer	SS A2-70	
5	Bolt	SS A2-70	

DE	outlet	Length	width	weight	DE	outlet	Length	width	weight
	inch					mm			
50	3/4"	88	100	1.50	140	3/4"	208	120	5.50
	1"								
	1 1/4"								
	1 1/2"								
	2"								
63	3/4"	124	100	2.50	160	3/4"	230	120	7.00
	1"								
	1 1/4"								
	1 1/2"								
	2"								
75	3/4"	135	110	3.00	180	3/4"	250	140	7.50
	1"								
	1 1/4"								
	1 1/2"								
	2"								
90	3/4"	150	110	3.20	200	3/4"	280	140	10.00
	1"								
	1 1/4"								
	1 1/2"								
	2"								
110	3/4"	170	120	3.70	250	3/4"	330	180	14.00
	1"								
	1 1/4"								
	1 1/2"								
	2"								
125	3/4"	192	120	4.50	315	3/4"	400	180	17.00
	1"								
	1 1/4"								
	1 1/2"								
	2"								

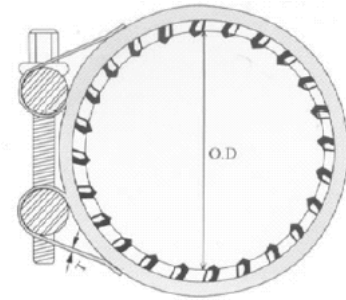
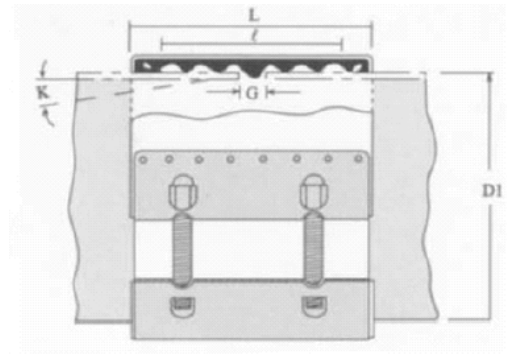

- For repair or install of all service pipes.
- Suitable for water and neutral liquids (sewage).
- Working temperature up to 70°C.
- Test conform to EN 12266.
- Light weight stainless steel construction design.
- EPDM gaskets.
- Ease of installation and dismantlement.
- Other materials, types and sizes on request.

Model	O. D. mm	O. D. Range mm	Length mm	Max. Expand mm	Pressure MP	kgf.cm	Weight Kg
RSH-S-20	27,20	26-28	57	30	2.5	50-80	0,2
RSH-S-25	34,00	33-35	57	30	2.5	50-80	0,2
RSH-S-32	42,70	42-44	57	30	2.5	50-100	0,35
RSH-S-40	48,00	47-49	57	30	2.5	50-100	0,35
RSH-S-50	60,00	59-62	80	46	2.5	100-150	0,8
RSH-S-65	76,00	75-78	80	46	2.5	100-150	0,86
RSH-S-80	89,00	88-92	107	65	1.6	150-200	1,6
RSH-S-100	108/114	106-117	107	65	1.6	150-200	1,8
RSH-S-125	140,00	137-143	116	69	1.6	250-300	3,0
RSH-S-150	159/168	156-171	116	69	1.6	250-300	3,2
RSH-S-200	219,00	216-222	155	80	1.2	400-800	7,0
RSH-S-250	273,00	270-276	155	80	1.2	400-800	7,9
RSH-S-300	325,00	322-328	155	80	1.0	800-1200	9,0
RSH-S-350	377,00	374-380	155	80	1.0	800-1200	11,0
RSH-S-400	426,00	423-429	155	80	1.0	800-1200	12,3
RSH-S-450	480,00	476-484	155	80	1.0	800-1200	13,0
RSH-S-500	530,00	526-534	155	80	1.0	1200-1500	14,1

Plate Flanges, DIN2573, PN6

FF 70

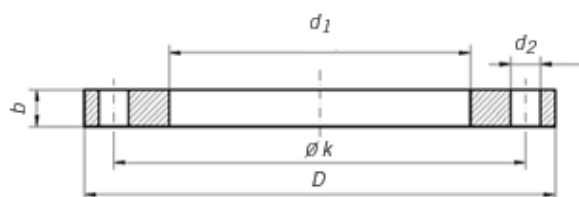

- Suitable for water and neutral liquids (sewage).
- Painting: yellow, black, oil, zin.
- Conform to DIN, EN, ANSI norms (on request)
- Available in following raw materials:
carbon steel = ASTM A105 - C22,8 - RST37,2
stainless steel = ASTM A182 F304 - F316L

Pipe			Flange					Screws			Weight of a flange (7,85 Kg/dm ³)
Rated Diameter	d1		d5	D	b	c	k	Number	Thread	d2	Kg
	ISO Series 1	DIN Series 2									
15	-	20	21	80	12	5	55	4	M 10	11	0,41
	21,3	-	22								
20	-	25	26	90	14	5	65	4	M 10	11	0,6
	26,9	-	27,6								
25	-	30	31	100	14	5	75	4	M 10	11	0,74
	33,7	-	34,4								
32	-	38	39	120	16	5	90	4	M 12	14	1,19
	42,4	-	43,1								
40	-	44,5	45,5	130	16	5	100	4	M 12	14	1,39
	48,3	-	49								
50	-	57	58,1	140	16	6	110	4	M 12	14	1,53
	60,3	-	61,1								
65	76,1	-	77,1	160	16	6	130	4	M 12	14	1,89
80	88,9	-	90,3	190	18	7	150	4	M 16	18	2,98
100	-	108	110	210	18	7	170	4	M 16	18	3,46
	114,3	-	116								
125	-	133	135	240	20	7	200	8	M 16	18	4,6
	139,7	-	142								
150	-	159	161	265	20	7	225	8	M 16	18	5,22
	168,3	-	171								
200	219,1	-	222	320	22	7	280	8	M 16	18	7,15
250	-	267	270	375	24	7	335	12	M 16	18	9,61
	273	-	276								
300	323,9	-	328	440	24	7	395	12	M 20	22	12,6
350	355,6	-	360	490	26	7	445	12	M 20	22	15,6
	-	368	372								
400	406,4	-	411	540	28	7	495	16	M 20	22	18,4
	-	419	424								
(450)*	457	-	463	595	30	7	550	16	M 20	22	21,4
500	508	-	532	645	30	7	600	20	M 20	22	24,6

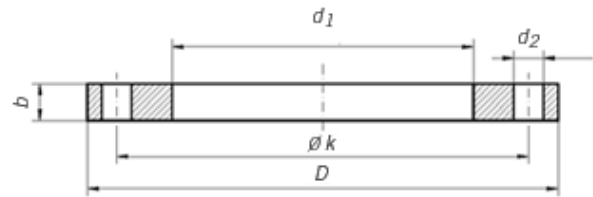

- Suitable for water and neutral liquids (sewage).
- Painting: yellow, black, oil, zin.
- Confirm to DIN, EN, ANSI norms (on request)
- Available in following raw materials:
carbon steel = ASTM A105 - C22,8 - RST37,2
stainless steel = ASTM A182 F304 - F316L

Pipe			Flange					Screws			Weight of a flange (7,85 Kg/dm3)
Rated	d1		d5	D	b	c	k	Number	Thread	d2	Kg
Diameter	ISO Series 1	DIN Series 2									
15	-	20	21	95	14	5	65	4	M 12	14	0,675
	21,3	-	22								0,669
20	-	25	26	105	16	5	75	4	M 12	14	0,749
	26,9	-	27,6								0,936
25	-	30	31	115	16	5	85	4	M 12	14	1,14
	33,7	-	34,4								1,11
32	-	38	39	140	16	5	100	4	M 16	18	1,66
	42,4	-	43,1								1,62
40	-	44,5	45,5	150	16	5	110	4	M 16	18	1,89
	48,3	-	49								1,86
50	-	57	58,1	165	18	6	125	4	M 16	18	2,51
	60,3	-	61,1								2,47
65	76,1	-	77,1	185	18	6	145	4	M 16	18	3
80	88,9	-	90,3	200	20	7	160	8	M 16	18	3,79
100	-	108	110	220	20	7	180	8	M 16	18	4,2
	114,3	-	116								4,03
125	-	133	135	250	22	7	210	8	M 16	18	5,71
	139,7	-	142								5,46
150	-	159	161	285	22	7	240	8	M 20	22	6,72
	168,3	-	171								6,57
200	219,1	-	222	340	24	7	295	8	M 20	22	9,31
250	-	267	270	395	26	7	350	12	M 20	22	12,5
	273	-	276								11,9
300	323,9	-	328	445	26	7	400	12	M 20	22	13,8
350	355,6	-	360	505	28	7	460	16	M 20	22	20,6
	-	368	372								19
400	406,4	-	411	565	32	7	515	16	M 24	26	27,9
	-	419	424								25,9
450	457	-	463	615	38	7	565	20	M 24	26	35,6
500	508	-	514	670	38	7	620	20	M 24	26	41,1

Welding Neck Flanges, DIN2631, PN6

FF 72

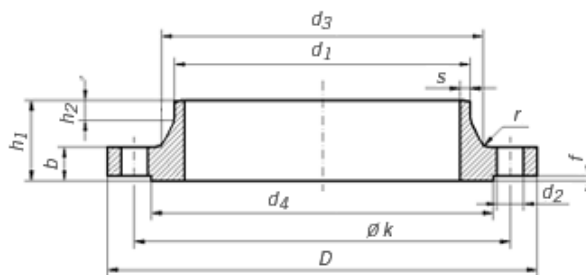
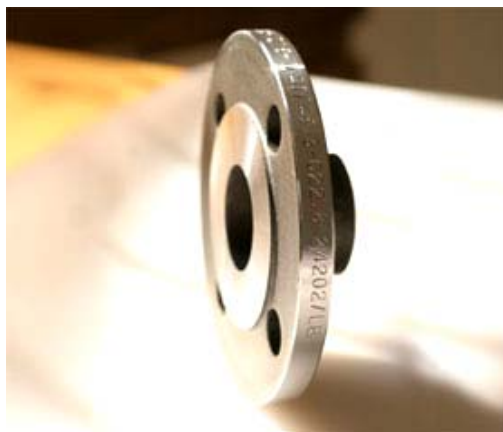

- Suitable for water and neutral liquids (sewage).
- Painting: yellow, black, oil, zin.
- Confirm to DIN, EN, ANSI norms (on request)
- Available in following raw materials:
carbon steel = ASTM A105 - C22,8 - RST37,2
stainless steel = ASTM A182 F304 - F316L

Pipe			Flange				Neck				Raised face	Screws			Weight of a flange (7,85 Kg/dm ³)	
Rated	d1		D	b	k	h1	d3	s	r	h2	d4	f	Number	Thread	d2	Kg
Diameter	ISO Series 1	DIN Series 2														
15	-	20	80	12	55	30	28	2	4	6	40	2	4	M 10	11	0,392
	21,3	-					30									
20	-	25	90	14	65	32	35	2	4	6	50	2	4	M 10	11	0,592
	26,9	-					38									
25	-	30	100	14	75	35	40	3	4	6	60	2	4	M 10	11	0,747
	33,7	-					42									
32	-	38	120	14	90	35	50	3	6	6	70	2	4	M 12	14	1,05
	42,4	-					55									
40	-	44,5	130	14	100	38	58	3	6	7	80	3	4	M 12	14	1,18
	48,3	-					62									
50	-	57	140	14	110	38	70	3	6	8	90	3	4	M 12	14	1,34
	60,3	-					74									
65	76,1	-	160	14	130	38	88	3	6	9	110	3	4	M 12	14	1,67
80	88,9	-	190	16	150	42	102	3	8	10	128	3	4	M 16	18	2,71
100	-	108	210	16	170	45	122	4	8	10	148	3	4	M 16	18	3,24
	114,3	-					130									
125	-	133	240	18	200	48	148	4	8	10	178	3	8	M 16	18	4,49
	139,7	-					155									
150	-	159	265	18	225	48	172	5	10	12	202	3	8	M 16	18	5,15
	168,3	-					184									
200	219,1	-	320	20	280	55	236	6	10	15	258	3	8	M 16	18	7,78
250	-	267	375	22	335	60	282	6	12	15	312	3	12	M 16	18	10,8
	273	-					290									
300	323,9	-	440	22	395	62	342	7	15	15	365	4	12	M 20	22	14
350	355,6	-	490	22	445	62	385	7	12	15	415	4	12	M 20	22	18,5
	-	368														16,7
400	406,4	-	540	22	495	65	438	7	12	15	465	4	16	M 20	22	21,2
	-	419														19
500	508	-	645	24	600	68	538	7	12	15	570	4	20	M 20	22	28,6
600	610	-	755	24	705	70	640	7	12	16	670	5	20	M 24	26	31,5
700	711	-	860	24	810	70	740	7	12	16	775	5	24	M 24	26	37,4
800	813	-	975	24	920	70	842	7	12	16	880	5	24	M 27	30	46,1
900	914	-	1075	26	1020	70	942	7	12	16	980	5	24	M 27	30	55,6
1000	1016	-	1175	26	1120	70	1045	7	16	16	1080	5	28	M 27	30	61,9
1200	1220	-	1405	28	1340	90	1248	8	16	20	1295	5	32	M 30	33	100
1400	1420	-	1630	32	1560	90	1452	8	16	20	1510	5	36	M 33	36	149
1600	1620	-	1830	34	1760	90	1655	9	16	20	1710	5	40	M 33	36	180
1800	1820	-	2045	36	1970	100	1855	10	16	20	1920	5	44	M 36	39	225

Welding Neck Flanges, DIN2632, PN10

FF 73

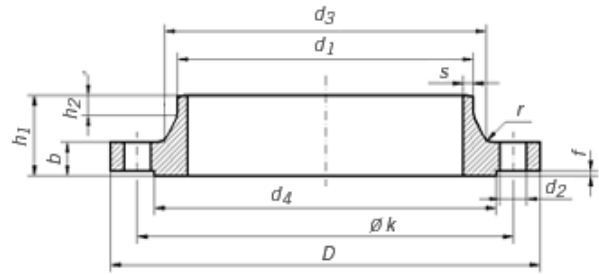

- Suitable for water and neutral liquids (sewage).
- Painting: yellow, black, oil, zin.
- Confirm to DIN, EN, ANSI norms (on request)
- Available in following raw materials:
carbon steel = ASTM A105 - C22,8 - RST37,2
stainless steel = ASTM A182 F304 - F316L

Pipe		Flange				Neck				Raised face		Screws		Weight of a flange (7,85 Kg/dm ³)	
Rated	d1	D	b	k	h1	d3	s	r	h2	d4	f	Number	Thread	d2	Kg
Diameter	ISO Series 1														
15	-	95	14	65	35	30	2	4	6	45	2	4	M 12	14	0,648
	21,3														
20	-	105	16	75	38	38	2	4	6	58	2	4	M 12	14	0,952
	26,9														
25	-	115	16	85	38	42	3	4	6	68	2	4	M 12	14	1,14
	33,7														
32	-	140	16	100	40	52	3	6	6	78	2	4	M 16	18	1,69
	42,4														
40	-	150	16	110	42	60	3	6	7	88	3	4	M 16	18	1,86
	48,3														
50	-	165	18	125	45	72	3	6	8	102	3	4	M 16	18	2,53
	60,3														
65	76,1	185	18	145	45	90	3	6	10	122	3	4	M 16	18	3,06
80	88,9	200	20	160	50	105	3	8	10	138	3	8	M 16	18	3,7
100	-	220	20	180	52	125	4	8	12	158	3	8	M 16	18	4,62
	114,3														
125	-	250	22	210	55	150	4	8	12	188	3	8	M 16	18	6,3
	139,7														
150	-	285	22	240	55	175	5	10	12	212	3	8	M 20	22	7,75
	168,3														
200	219,1	340	24	295	62	235	6	10	16	268	3	8	M 20	22	11,3
	-														
250	273	395	26	350	68	285	6	12	16	320	3	12	M 20	22	14,7
	-														
300	323,9	445	26	400	68	344	7	12	16	370	4	12	M 20	22	17,4
350	355,6	505	26	460	68	385	7	12	16	430	4	16	M 20	22	23,6
	-														368
400	406,4	565	26	515	72	440	7	12	16	482	4	16	M 24	26	28,6
	-														419
-450	457	615	28	565	72	488	7	12	16	532	4	20	M 24	26	31,5
500	508	670	28	620	75	542	7	12	16	585	4	20	M 24	26	38,1
600	610	780	28	725	80	642	7	12	18	685	5	20	M 27	30	44,6
700	711	895	30	840	80	745	8	12	18	800	5	24	M 27	30	62,4
800	813	1015	32	950	90	850	8	12	18	905	5	24	M 30	33	84,1
900	914	1115	34	1050	95	950	10	12	20	1005	5	28	M 30	33	98,5
1000	1016	1230	34	1160	95	1052	10	16	20	1110	5	28	M 33	36	115

Welding Neck Flanges, DIN2633, PN16

FF 74

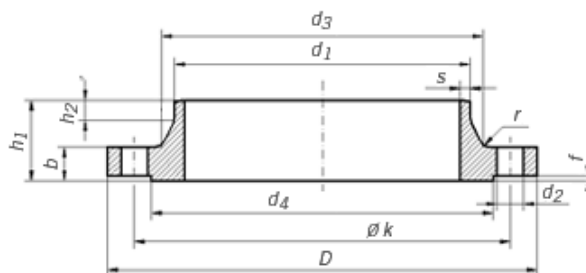

- Suitable for water and neutral liquids (sewage).
- Painting: yellow, black, oil, zin.
- Confirm to DIN, EN, ANSI norms (on request)
- Available in following raw materials:
carbon steel = ASTM A105 - C22,8 - RST37,2
stainless steel = ASTM A182 F304 - F316L

Pipe		Flange				Neck				Raised face	Screws			Weight of a flange (7,85 Kg/dm ³)		
Rated	d1		D	b	k	h1	d3	s	r	h2	d4	f	Number	Thread	d2	Kg
Diameter	ISO Series 1	DIN Series 2														
15	-	20	95	14	65	35	30	2	4	6	45	2	4	M 12	14	0,648
	21,3	-					32									
20	-	25	105	16	75	38	38	2,3	4	6	58	2	4	M 12	14	0,952
	26,9	-					40									
25	-	30	115	16	85	38	42	2,6	4	6	68	2	4	M 12	14	1,14
	33,7	-					45									
32	-	38	140	16	100	40	52	2,6	6	6	78	2	4	M 16	18	1,69
	42,4	-					56									
40	-	44,5	150	16	110	42	60	2,6	6	7	88	3	4	M 16	18	1,86
	48,3	-					64									
50	-	57	165	18	125	45	72	2,9	6	8	102	3	4	M 16	18	2,53
	60,3	-					75									
65	76,1	-	185	18	145	45	90	2,9	6	10	122	3	4	M 16	18	3,06
80	88,9	-	200	20	160	50	105	3,2	8	10	138	3	8	M 16	18	3,7
100	-	108	220	20	180	52	125	3,6	8	12	158	3	8	M 16	18	4,62
	114,3	-					131									
125	-	133	250	22	210	55	150	4	8	12	188	3	8	M 16	18	6,3
	139,7	-					156									
150	-	159	285	22	240	55	175	4,5	10	12	212	3	8	M 20	22	7,75
	168,3	-					184									
-175	193,7	-	315	24	270	60	210	5,4	10	12	242	3	8	M 20	22	9,85
200	219,1	-	340	24	295	62	235	5,9	10	16	268	3	12	M 20	22	11
250	-	267	405	26	355	70	285	6,3	12	16	320	3	12	M 24	26	15,6
	273	-					292									
300	323,9	-	460	28	410	78	344	7,1	12	16	378	4	12	M 24	26	22
350	355,6	-	520	30	470	82	390	8	12	16	438	4	16	M 24	26	31,2
	-	368														28,8
400	406,4	-	580	32	525	85	445	8	12	16	490	4	16	M 27	30	39,3
	-	419														36,3
-450	457	-	640	34	585	85	490	8	12	16	550	4	20	M 27	30	44,3
500	508	-	715	34	650	90	548	8	12	16	610	4	20	M 30	33	61
600	610	-	840	36	770	95	652	8,8	12	18	725	5	20	M 33	36	75,4
700	711	-	910	36	840	100	755	8,8	12	18	795	5	24	M 33	36	77
800	813	-	1025	38	950	105	855	10	12	20	900	5	24	M 36	39	101

Threaded Flanges, DIN2565, PN6

FF 75

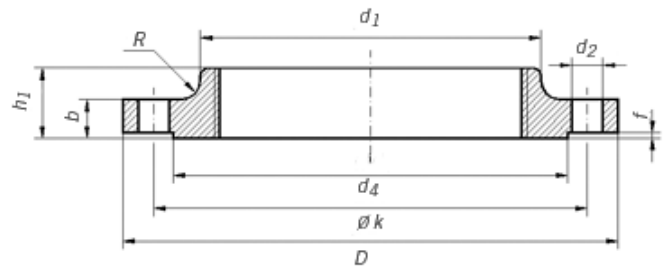

- Suitable for water and neutral liquids (sewage).
- Painting: yellow, black, oil, zin.
- Confirm to DIN, EN, ANSI norms (on request)
- Available in following raw materials:
carbon steel = ASTM A105 - C22,8 - RST37,2
stainless steel = ASTM A182 F304 - F316L

Rated Diameter	d1	Flange					Neck d3	Raised face d4	f	Screws			Weight of a flange (7,85 Kg/dm3) Kg
		Thread	D	b	k	h1				Number	Thread	d2	
15	21,3	R 1/2	80	12	55	20	30	40	2	4	M 10	11	0,373
20	26,9	R 3/4	90	14	65	24	40	50	2	4	M 10	11	0,59
25	33,7	R 1	100	14	75	24	50	60	2	4	M 10	11	0,743
32	42,4	R 1 1/4	120	14	90	26	60	70	2	4	M 12	14	1,05
40	48,3	R 1 1/2	130	14	100	26	70	80	3	4	M 12	14	1,2
50	60,3	R 2	140	14	110	28	80	90	3	4	M 12	14	1,37
65	76,1	R 2 1/2	160	14	130	32	100	110	3	4	M 12	14	1,92
80	88,9	R 3	190	16	150	34	110	128	3	4	M 16	18	2,82
100	114	R 4	210	16	170	38	130	148	3	4	M 16	18	3,19
125	140	R 5	240	18	200	40	160	178	3	8	M 16	18	4,47
150	165	R 6	265	18	225	44	185	202	3	8	M 16	18	5,3

Threaded Flanges, DIN2566, PN10/PN16

FF 76

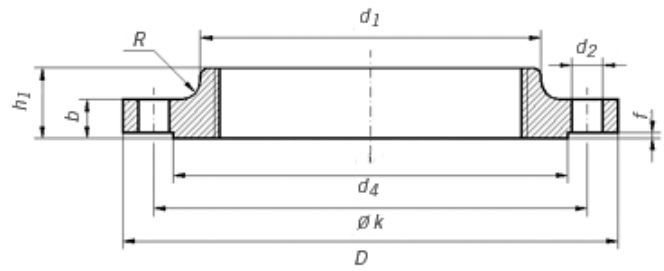

- Suitable for water and neutral liquids (sewage).
- Painting: yellow, black, oil, zin.
- Confirm to DIN, EN, ANSI norms (on request)
- Available in following raw materials:
carbon steel = ASTM A105 - C22,8 - RST37,2
stainless steel = ASTM A182 F304 - F316L

Rated Diameter	d1	Flange					Neck d3	Raised face d4	f	Screws			Weight of a flange
		Thread	D	b	k	h1				Number	Thread	d2	(7,85 Kg/dm3) Kg
15	21,3	R 1/2	95	14	65	20	35	45	2	4	M 12	14	0,613
20	26,9	R 3/4	105	16	75	24	45	58	2	4	M 12	14	0,91
25	33,7	R 1	115	16	85	24	52	68	2	4	M 12	14	1,1
32	42,4	R 1 1/4	140	16	100	26	60	78	2	4	M 16	18	1,6
40	48,3	R 1 1/2	150	16	110	26	70	88	3	4	M 16	18	1,78
50	60,3	R 2	165	18	125	28	85	102	3	4	M 16	18	2,43
65	76,1	R 2 1/2	185	18	145	32	105	122	3	4	M 16	18	3,18
80	88,9	R 3	200	20	160	34	118	138	3	8	M 16	18	4,12
100	114	R 4	220	20	180	38	140	158	3	8	M 16	18	4,47
125	140	R 5	250	22	210	40	168	188	3	8	M 16	18	6,13
150	165	R 6	285	22	240	44	195	212	3	8	M 20	22	7,92

Blind Flanges, DIN2527, PN10

FF 77

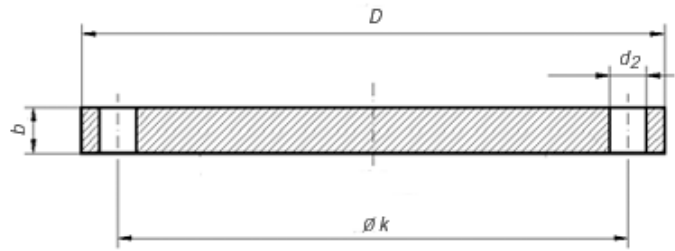

- Suitable for water and neutral liquids (sewage).
- Painting: yellow, black, oil, zin.
- Confirm to DIN, EN, ANSI norms (on request)
- Available in following raw materials:
carbon steel = ASTM A105 - C22,8 - RST37,2
stainless steel = ASTM A182 F304 - F316L

Rated Diameter	Flange			Screws			Weight of a flange (7,85 Kg/dm3)
	D	b	k	Number	Thread	d2	Shape B Kg
15	95	14	65	4	M 12	14	0,72
20	105	16	75				1,01
25	115	16	85				1,23
32	140	16	100				1,8
40	150	16	110		M 16	18	2,09
50	165	18	125				2,88
65	185	18	145				3,66
80	200	20	160				4,77
100	220	20	180	8	M 20	22	5,65
125	250	22	210				8,42
150	285	22	240				10,4
200	340	24	295				16,5
250	395	26	350	12	M 20	22	24
300	445	26	400				30,9
350	505	26	460	16	M 24	26	40,6
400	565	26	515				49,4
500	670	28	620	20	M 24	26	75

Blind Flanges, DIN2527, PN16

FF 78

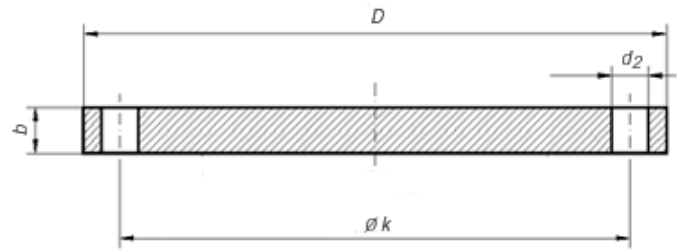

- Suitable for water and neutral liquids (sewage).
- Painting: yellow, black, oil, zin.
- Confirm to DIN, EN, ANSI norms (on request)
- Available in following raw materials:
carbon steel = ASTM A105 - C22,8 - RST37,2
stainless steel = ASTM A182 F304 - F316L

Rated Diameter	Flange			Screws			Weight of a flange (7,85 Kg/dm3)
	D	b	k	Number	Thread	d2	Shape B Kg
15	95	14	65	4	M 12	14	0,72
20	105	16	75				1,01
25	115	16	85				1,23
32	140	16	100		M 16	18	1,8
40	150	16	110				2,09
50	165	18	125				2,88
65	185	18	145	3,66			
80	200	20	160	4,77			
100	220	20	180	8	M 20	22	5,65
125	250	22	210				8,42
150	285	22	240				10,4
200	340	24	295	12	M 24	26	16,1
250	405	26	355				24,9
300	460	28	410				35,1
350	520	30	470	16	M 27	30	47,8
400	580	32	525				63,5
500	715	36	650	20	M 30	33	102

Ductile Iron Push-on Joint Socket Fittings which conform to Product standards: BS-EN-545: 1995 / ISO-2531:1998 / IS-9523: 2000. We also supply D.I. Fittings which are suitable for both Mechanical Joint and Pushon Joint conforming to BSEN: 545/1995 and IS:9523/2000.

The mechanical properties of Fittings (representative of finished products) are tested for tensile strength (Min 420 Mpa), hardness (Max 230 BHN) and elongation (Min 5%) to verify mechanical properties.

All Ductile Iron fittings are tested at the following test pressure as specified in ISO : 2531 / BSEN: 545/1995 AND IS : 9523.

For hydrostatic test, the fittings are kept under pressure for 10 seconds. They withstand the pressure test without showing any sign of leakage, sweating or other defect of any kind. The test is conducted before the application of surface coating.

Diameter mm	Works Test Pressure (kg/cm ²)
80-300	25
350-600	16
700-1200	10
900-1200	10

Dimensions of Push-on and Mechanical Joint Fittings.

DN	External Diameter DE (mm)		Wall Thickness, DE (mm)	
	Nominal	Tolerance	K12	Tolerance
80	98	+1/-2.7	7.0	-2.38
100	118	+1/-2.8	7.2	-2.40
125	144	+1/-2.8	7.5	-2.42
150	170	+1/-2.9	7.8	-2.45
200	222	+1/-3.0	8.4	-2.50
250	274	+1/-3.1	9.0	-2.55
300	326	+1/-3.3	9.6	-2.60
350	378	+1/-3.4	10.2	-2.65
400	429	+1/-3.5	10.8	-2.70
450	480	+1/-3.6	11.4	-2.75
500	532	+1/-3.8	12.0	-2.80
600	635	+1/-4.0	13.2	-2.90
700	738	+1/-4.3	14.4	-3.0
750	790	+1/-4.4	15.0	-3.05
800	842	+1/-4.5	15.6	-3.10
900	945	+1/-4.8	16.8	-3.20
1000	1048	+1/-5.0	18.0	-3.30
1100	1152	+1/-5.4	19.2	-3.4

It may appear that the test pressure for fittings are low compared to the allowable working pressures in pipes. But fittings with K12 thickness of ductile iron cannot burst at allowable working pressures of pipes.

Due to practical difficulties, fittings are not tested at the factory to very high pressures. BS : 8010 Section 2.1 British Standard Code of Practice for Pipeline Part 2 (Section 2.1 - Ductile Iron) Clause 13 says, "Practical considerations limit the works hydrostatic test pressure to values which may be lower than the site test pressure". The same comment is mentioned in IS : 9523/2000 also. The above pressures are sufficient to detect any casting flaw. After the pipeline is laid and fittings are in position and provided with proper anchorage, the entire pipeline can be pressure tested at a much higher pressure than the works test pressure.

Ductile Cast Iron Fittings, Technical Details

Dimensions of Flange Drilling for Flange Fittings-PN 10

All dimensions in millimeters										
Nominal Dimensions Diameter								Holes		Bolt Size metric
DN	D	E	C	b	f	a	s	Nos.	Dia (d)	
80	200	132	160	16	3	19	15	4	19	M16
100	220	156	180	16	3	19	15	8	19	M16
125	250	184	210	16	3	19	15	8	19	M16
150	285	211	240	16	3	19	15	8	23	M20
200	340	266	295	17	3	20	15	8	23	M20
250	395	319	350	19	3	22	16	12	23	M20
300	445	370	400	20.5	4	24.5	17.5	12	23	M20
350	505	429	460	20.5	4	24.5	19.5	16	23	M20
400	565	480	515	20.5	4	24.5	19.5	16	28	M24
450	615	530	565	21	4	24.5	20	20	28	M24
500	670	582	620	22.5	4	26.5	21	20	28	M24
600	780	682	725	25	5	30	24	20	31	M27
700	895	794	840	27.5	5	32.5	24	24	31	M27
750	960	857	900	29	5	34	24	24	31	M27
800	1015	901	950	30	5	35	24.5	24	34	M30
900	1115	1001	1050	32	5	37.5	26.5	28	34	M30
1000	1230	1112	1160	35	5	40	28	28	37	M33
1100	1340	1231	1270	38	5	43	30	28	37	M33

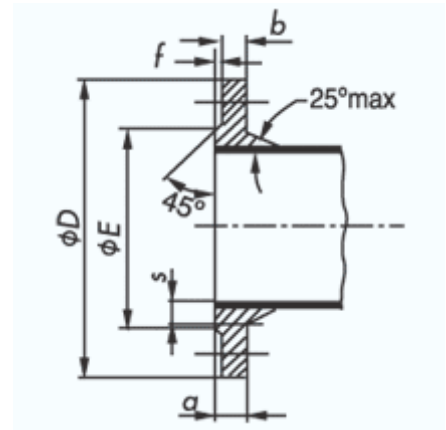

Dimensions of Flange Drilling for Flange Fittings-PN 16

All dimensions in millimeters										
N. Dia	Dim.							Holes		Bolt Size metric
DN	D	E	C	b	f	a	s	Nos.	Dia (d)	-
80	200	132	160	16	3	19	15	8	19	M16
100	220	156	180	16	3	19	15	8	19	M16
125	250	184	210	16	3	19	15	8	19	M16
150	285	211	240	16	3	19	15	8	23	M20
200	340	266	295	17	3	20	16	12	23	M20
250	400	319	355	19	3	22	17.5	12	28	M24
300	455	370	410	20.5	4	24.5	19.5	12	28	M24
350	520	429	470	22.5	4	26.5	21	12	28	M24
400	580	480	525	24	4	28	22.5	16	31	M27
450	640	548	585	26	4	30	24	16	31	M27
500	715	609	650	27.5	4	31.5	25	20	34	M30
600	840	720	770	31	5	36	27	20	37	M33
700	910	794	840	34.5	5	39.5	27.5	24	37	M33
750	970	857	900	36	5	41	28	24	37	M33
800	1025	901	950	38	5	43	30	24	40	M36
900	1125	1001	1050	41	5	46	32.5	28	40	M36
1000	1255	1112	1170	45	5	50	35	28	43	M39
1100	1355	1218	1270	48.5	5	53.5	37.5	32	43	M39

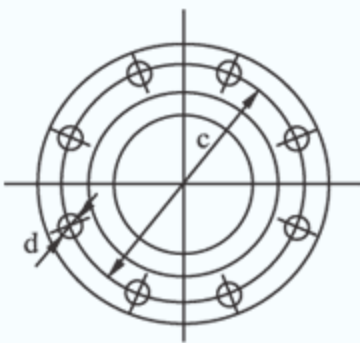

Tolerance on Lengths

Types of castings	Tolerance (mm)
Fittings for socketted joints	±20
Fittings for flanged joints	±10*

The Permissible Deviations of the Lengths of Fittings

Types of fittings	Nominal diameter DN mm	Deviation in L and H mm
Flanged sockets/ Flanged spigots / collars, tapers	80-1000	±25
Tees		80-1000+50/-25
Bends 90 (1/4)	80-1000	±(15+0.03 DN)
Bends 45 (1/8)	80-1000	±(10+0.025 DN)
Bends 22 30' and 11 15'	80-1000	±(10+0.02 DN)

Tolerance on Thickness of Flange

Type of Flange	Tolerance
Integrally cast flanges	± (3+0.05b)
Welded and screwed on Flanges	± (2+0.05b)

Push-on Joint Fittings - Allowable Ovality

Nominal Diameter DN	Allowable difference between Minor Axis and D _{EMin}
mm	mm
80-300	1.0
350-600	1.75
700	2.0
750-800	2.4
900-1100	3.5

Push-on Joint Fittings - Allowable Ovality

Nominal Diameter DN	Allowable ovality of Spigot of External diameters D _E
mm	mm
80-150	5
200-350	10
400-450	20
600-800	30
900-1100	40

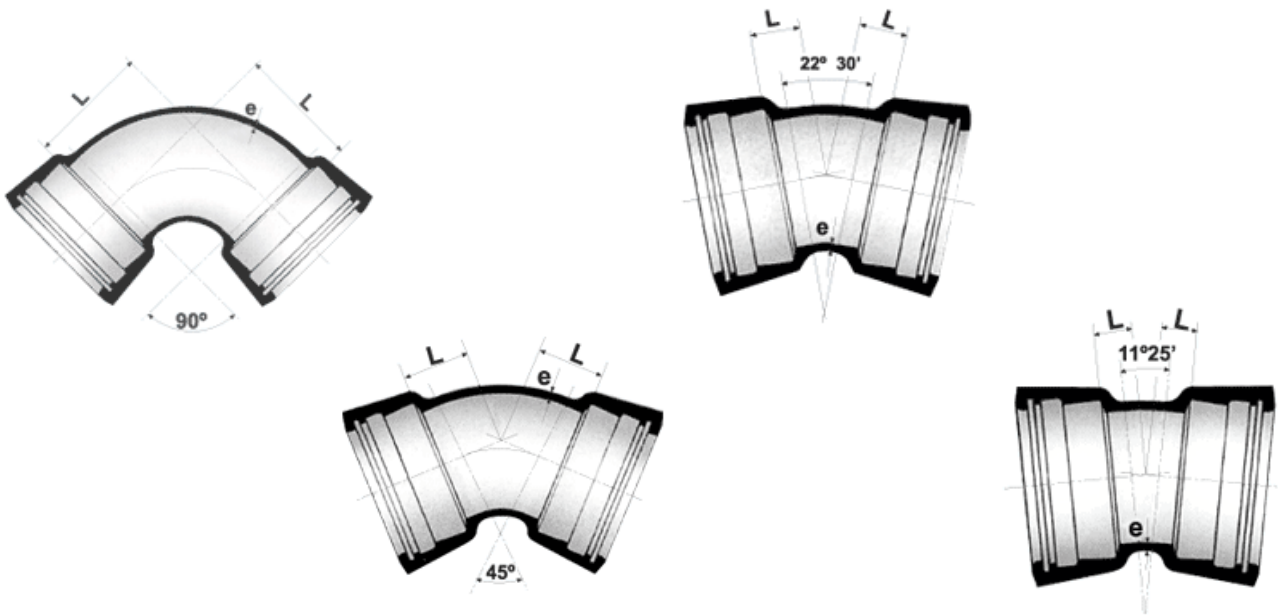

Nominal	e	90°	45°	0°	11.25°
Dia					
mm	mm	mm	mm	mm	mm
80	7.0	100	55	40	30
100	7.2	120	65	40	30
150	7.8	170	85	55	35
200	8.4	220	110	65	40
250	9.0	270	130	75	50
300	9.6	320	150	85	55
350	10.2		175	95	60
400	10.8		195	110	65
450	11.4		220	120	70
500	12.0		240	130	75
600	13.2		285	150	85
700	14.4		330	175	95
750	15.0		350	185	100
800	15.6		370	195	110
900	16.4		415	205	115
1000	18.0		460	210	120
1100	19.2		505	220	120

Ductile Cast Iron Fittings, 90° Duck-Foot Double Socket Bend

DI 44

Nominal Dia	e	L	c	d
mm	mm	mm	mm	mm
80	7.0	110	110	180
100	7.2	130	125	200
150	7.8	180	160	250
200	8.4	230	190	300
250	9.0	280	225	350
300	9.6	325	255	400
350	10.2	380	290	450
400	10.8	430	320	500
450	11.4	480	355	550
500	12.0	530	385	600
600	13.2	630	450	700
700	14.4	735	515	800
750	15.0	790	545	850
800	15.6	830	580	900
900	16.8	930	645	1000
1000	18.0	1035	710	1100

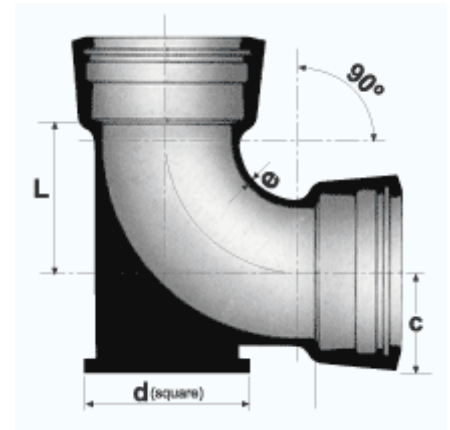

Ductile Cast Iron Fittings, 90° Double Socket Concentric Tapers

DI 45

DN Body	DN Branch	e1	e2	L
mm	mm	mm	mm	mm
100	80	7.2	7.0	90
150	80	7.8	7.0	190
150	100	7.8	7.2	150
200	100	8.4	7.2	250
200	150	8.4	7.8	150
250	150	9.0	7.8	250
250	200	9.0	8.4	150
300	150	9.6	7.8	350
300	200	9.6	8.4	250
300	250	9.6	9.0	150
350	200	10.2	8.4	360
350	250	10.2	9.0	260
350	300	10.2	9.6	160
400	250	10.8	9.0	360
400	300	10.8	9.6	260
400	350	10.8	10.2	160
450	350	11.4	10.2	260
450	400	11.4	10.8	169
500	350	12.0	10.2	360
500	400	12.0	10.8	260
600	400	13.2	10.8	460
600	500	13.2	12.0	260
700	500	14.4	12.0	480
700	600	14.4	13.2	280
800	600	15.6	13.2	480
800	700	15.6	14.4	280

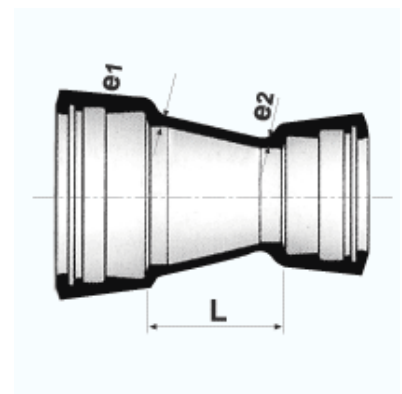

All Socket Tee and Double Socket Branch Flanged Tee

DI 46/DI47

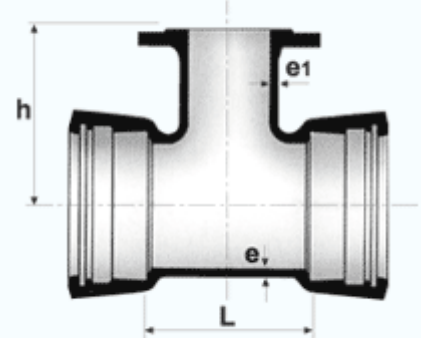
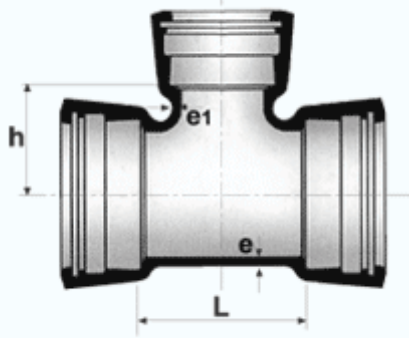

Nominal Dia		L			H		
dN	dN	e	e1	Branch	All Socket	Flange on	All Socket
Body	Branch			Flange on		Double	
				Double		Socket	
mm	mm	mm	mm	Socket	mm	mm	mm
80	80	7	7	170	170	165	85
100	80	7.2	7	170	170	175	95
100	100	7.2	7.2	190	190	180	95
150	100	7.8	7.2	195	195	210	120
200	80	8.4	7	175	175	235	145
200	100	8.4	7.2	200	200	240	145
200	150	8.4	7.8	255	255	250	150
200	200	8.4	8.4	315	315	260	155
250	80	9	7	180	180	265	170
250	100	9	7.2	200	200	270	170
250	150	9	7.8	260	260	280	175
250	200	9	8.4	315	315	290	180
250	250	9	9.6	375	375	300	190
300	100	9.6	7.2	210	210	300	220
300	200	9.6	8.4	325	325	320	220
300	300	9.6	9.6	440	440	340	200
350	100	10.2	7.2	205	-	330	-
350	200	10.2	8.4	325	-	350	-
350	350	10.2	10.2	495	-	380	-
400	80	10.8	7.0	185	-	355	-
400	100	10.8	7.2	210	-	360	-
400	150	10.8	7.8	270	-	370	-
400	200	10.8	8.4	325	-	380	-
400	300	10.8	9.6	440	-	400	-
400	400	10.8	10.8	560	-	420	-
450	100	11.4	7.2	215	-	390	-
450	250	11.4	9.0	390	-	420	-
450	450	11.4	11.4	620	-	460	-
500	100	12.0	7.2	215	-	420	-
500	200	12.0	8.4	330	-	440	-
500	400	12.0	10.8	565	-	480	-
500	500	12.0	12.0	680	-	500	-
600	200	13.2	8.4	340	-	500	-
600	400	13.2	10.8	570	-	540	-
600	600	13.2	13.2	800	-	580	-
700	200	14.4	8.4	345	-	525	-
700	400	14.4	10.8	575	-	555	-

DI 47

Nominal Dia DN	e	L	d
mm	mm	mm	mm
80	7.0	160	109
100	7.2	160	130
150	7.8	165	183
200	8.4	170	235
250	9.0	175	288
300	9.6	180	340
400	10.8	190	445
450	11.4	195	498
500	12.0	200	550
600	13.2	210	655
700	14.4	220	760
750	15.0	225	810
800	15.6	230	865
900	16.8	240	970
1000	18.0	250	1075

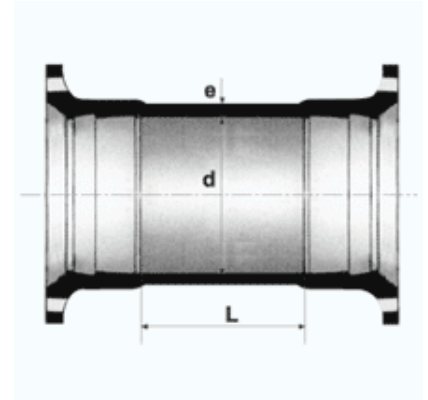

DI 48/DI 49

Ductile Cast Iron Fittings, Mechanical Joint 90° & 45°

Nominal Dia DN	90° BEND		45° BEND	
	L	r approx	L	r approx
	mm	mm	mm	mm
100	120	95	65	100
150	170	145	85	145
200	220	195	110	30.5
250	270	245	130	245
300	320	290	155	305
350	370	340	175	350
400	420	390	200	405
450	470	435	220	450
500	520	485	240	495
600	620	580	285	595

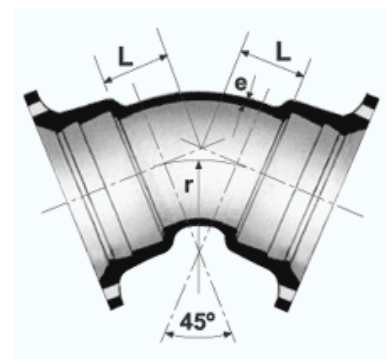
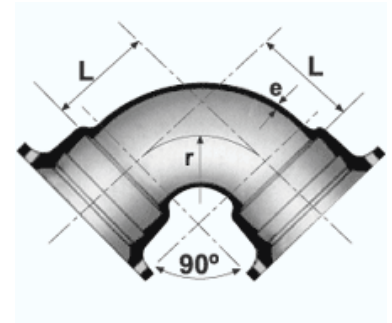

Ductile Cast Iron Fittings, Mechanical Joint 22° 30' & 11° 15' BEND

DI 50/DI 51

Nominal Dia DN	22° 30' BEND		11° 15' BEND	
	L	r approx	L	r approx
	mm	mm	mm	mm
100	45	110	35	120
150	55	155	40	155
200	65	195	45	195
250	75	240	50	230
300	90	305	60	315
350	100	350	65	350
400	110	390	70	385
450	120	435	75	420
500	135	505	85	510
600	155	590	95	580

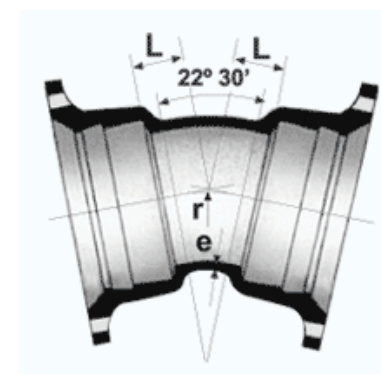
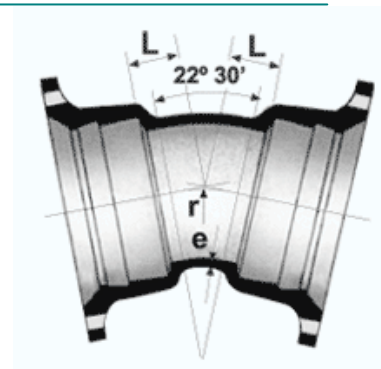

Ductile Cast Iron Fittings, Mechanical Joint Taper

DI 53

Large End DN	Small End DN	L
mm	mm	mm
150	100	150
200	100	250
200	150	150
250	150	250
250	200	150
300	150	350
300	200	250
300	250	150
350	200	360
350	250	360
350	300	160
400	200	460
400	250	360
400	300	260
400	350	160
450	250	460
450	300	360
450	350	260
450	400	160
500	250	560
500	300	460
500	350	360
500	400	260
500	450	160
600	300	660
600	350	560
600	400	460

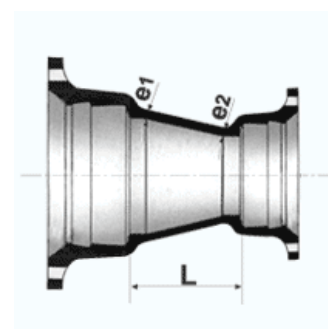

Ductile Cast Iron Fittings, Flanged Socked (Mechanical Joint)

DI 54

Nominal Size (DN)	L
mm	mm
100	130
150	135
200	140
250	145
300	150
350	155
400	160
450	165
500	170
600	180

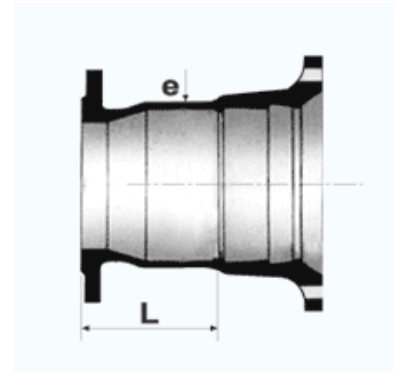

Ductile Cast Iron Fittings, Mechanical Joint Tees

DI 55/DI 56

ITEM	L	All Socket Tee H	Double Socket
			Branch Flange Tee H
100 x 80	185	125	195
100 x 100	210	125	200
150 x 80	190	150	220
150 x 100	210	150	230
150 x 150	270	150	245
200 x 80	190	180	250
200 x 100	315	180	255
200 x 150	270	180	270
200 x 200	330	180	275
250 x 80	220	205	275
250 x 100	200	210	285
250 x 150	335	210	300
250 x 200	335	210	305
250 x 250	390	210	320
300 x 80	220	235	305
300 x 100	220	235	310
300 x 150	335	235	325
300 x 200	335	235	330
300 x 250	450	240	345
330 x 300	450	240	360
350 x 80	225	260	330
350 x 100	225	260	340
350 x 150	340	265	355
350 x 200	340	265	360
350 x 250	515	265	375
350 x 300	515	270	390
350 x 350	515	270	405
400 x 80	225	290	360
400 x 100	225	290	365
400 x 150	340	290	380
400 x 200	340	290	385

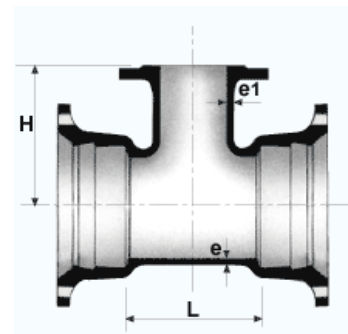
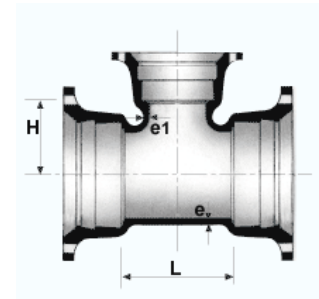

Ductile Cast Iron Fittings, Mechanical Joint Tees (cont.)

DI 57/DI 58

ITEM	L	All Socket Tee H	Double Socket
			Branch Flange Tee H
400 x 250	575	575	400
400 x 300	575	295	415
400 x 350	575	300	430
400 x 400	575	300	445
450 x 80	230	315	385
450 x 100	230	315	395
450 x 150	345	320	410
450 x 200	345	320	415
450 x 250	635	320	430
450 x 300	635	325	445
450 x 350	635	310	460
450 x 400	635	315	475
450 x 450	635	330	490
500 x 100	230	345	420
500 x 150	350	345	435
500 x 200	350	345	440
500 x 250	580	350	455
500 x 300	580	350	470
500 x 350	580	340	485
500 x 400	580	340	500
500 x 450	695	345	515
500 x 500	695	360	530
600 x 100	355	400	457
600 x 150	355	400	490
600 x 200	355	400	495
600 x 250	585	405	510
600 x 300	585	405	525
600 x 350	585	395	540
600 x 400	585	395	555
600 x 450	820	400	570
600 x 500	820	405	585
600 x 600	820	420	615

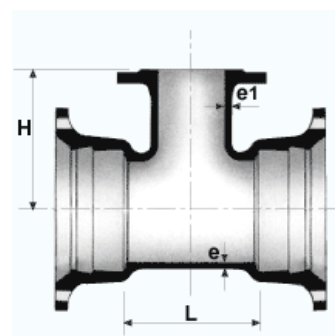
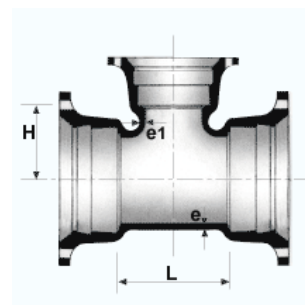

Ductile Cast Iron Fittings, Flanged Spigot

DI 60

Nominal Dia	DE	e	L
DN			
mm	mm	mm	mm
80	98	7.0	350
100	118	7.2	360
150	170	7,8	380
200	222	8.4	400
250	274	9.0	420
300	326	9.6	440
350	378	10.2	460
400	429	10.8	480
450	480	11.4	500
500	532	12.0	520
600	635	13.2	560
700	738	14.4	600
750	790	15.0	600
800	842	15.6	600
900	945	16.8	600
1000	1048	18.0	600
1100	1152	19.2	600

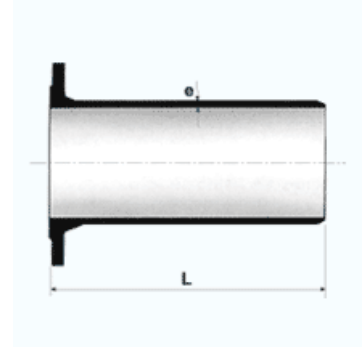

Ductile Cast Iron Fittings, Blank Flanges

DI 62

Nominal Dia	a	b	D
DN			
mm	mm	mm	mm
80	19.0	16.0	200
100	19.0	16.0	220
150	19.0	16.0	285
200	20.0	17.0	340
250	22.0	19.0	400
300	24.5	20.5	455
350	26.5	22.5	520
400	28.0	24.0	580
450	30.0	26.0	640
500	31.5	27.5	775
600	36.0	31.0	840
700	36.0	34.5	910
750	41.0	36.0	970
800	43.0	38.0	1025
900	46.5	41.5	1125
1000	50.0	45.0	1255
1100	53.5	48.5	1355



Ductile Cast Iron Fittings, 90° Double Flanged Bend

DI 63

Nominal Dia	e	L
mm	mm	mm
80	7.0	165
100	7.2	180
150	7.8	220
200	8.4	260
250	9.0	350
300	9.6	400
350	10.2	450
400	10.8	500
450	11.4	550
500	12.0	600
600	13.2	700
700	14.4	800
750	15.0	850
800	15.6	900
900	16.8	1000
1000	18.0	1100
1100	18.0	1100

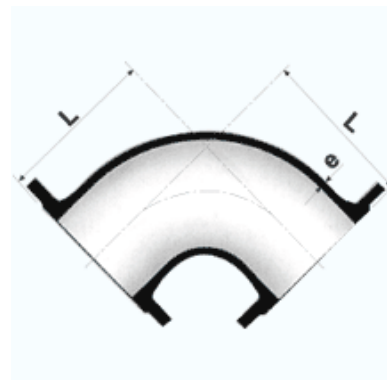

Ductile Cast Iron Fittings, 45° Double Flanged Bend

DI 64

Nominal Dia	e	L
mm	mm	mm
80	7.0	130
100	7.2	140
150	7.8	160
200	8.4	180
250	9.0	350
300	9.6	400
350	10.2	298
400	10.8	324
450	11.4	350
500	12.0	375
600	13.2	426
700	14.4	478
750	15.0	504
800	15.6	529
900	16.8	581
1000	18.0	632
1100	19.2	694

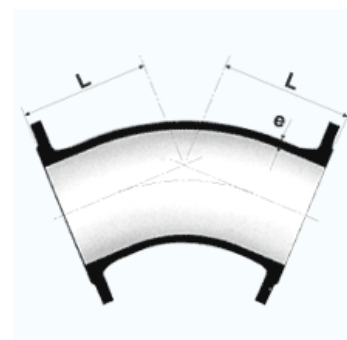

Ductile Cast Iron Fittings, 90° Duck Foot Double Flanged Bend

DI 66

Nominal Size	e	L	c	d
mm	mm	mm	mm	mm
80	7.0	155	110	180
100	7.2	175	125	200
150	7.8	230	160	250
200	8.4	280	190	300
250	9.0	335	225	350
300	9.6	385	255	400
350	10.2	440	290	450
400	10.8	495	320	500
450	11.4	545	355	550
500	12.0	600	385	600
600	13.2	705	450	700
700	14.4	810	515	800
750	15.0	860	550	850
800	15.6	915	580	900
900	16.8	1020	645	1000
1000	18.0	1130	710	1100

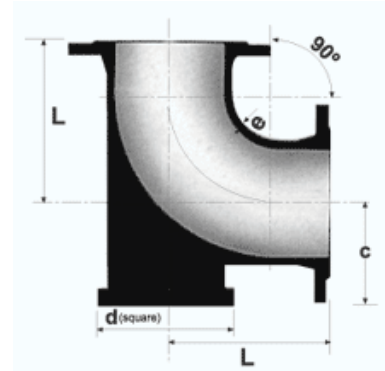

Ductile Cast Iron Fittings, Double Flanged Concentric Tapers

DI 67

DN Body	DN	e1	e2	L
	Branch			
mm	mm	mm	mm	mm
100	80	7.2	7.0	200
200	150	8.4	7.8	300
250	200	9.0	8.4	300
300	250	9.6	9.0	300
350	300	10.2	9.6	300
400	350	10.8	10.2	300
450	400	11.4	10.8	300
500	400	12.0	10.8	600
600	500	13.2	12.0	600
700	600	14.4	13.2	600
750	600	15.0	13.2	600
800	700	15.6	14.4	600
900	800	16.8	15.6	600
1000	900	18.0	16.8	600

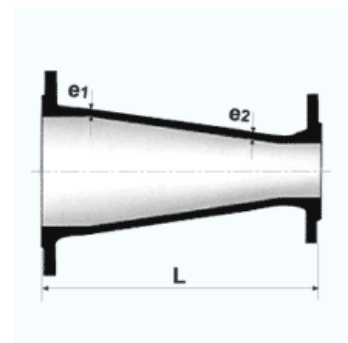

Ductile Cast Iron Fittings, All Flanged Tee

DI 68

Nominal Dia		e	e1	L	H
DN	DN				
Body	Branch	mm	mm	mm	mm
mm	mm				
80	80	7.0	7.0	330	165
100	80	7.2	7.0	360	175
100	100	7.2	7.2	360	180
150	80	7.8	7.0	440	205
150	100	7.8	7.2	440	210
150	150	7.8	7.8	440	220
200	80	8.4	7.0	520	235
200	100	8.4	7.2	520	240
200	150	8.4	7.8	520	250
200	200	8.4	8.4	520	260
250	100	9.0	7.2	700	275
250	200	9.0	8.4	700	325
250	250	9.0	9.0	700	350
300	100	9.6	7.2	800	300
300	200	9.6	8.4	800	350
300	300	9.6	9.6	800	400
350	100	10.2	7.2	850	325
350	200	10.2	8.4	850	325
350	350	10.2	10.2	850	425
400	100	10.8	7.2	900	350
400	200	10.8	8.4	900	350
400	400	10.8	10.8	900	450
450	100	11.4	7.2	950	375
450	200	11.4	8.4	950	375
450	450	11.4	11.4	950	475
500	100	12.0	7.2	1000	400
500	200	12.0	8.4	1000	400
500	400	12.0	10.8	1000	500
500	500	12.0	12.0	1000	500
600	200	13.2	8.4	1100	450
600	400	13.2	10.8	1100	550
600	600	13.2	13.2	1100	550
700	200	14.4	8.4	650	525
700	400	14.4	10.4	870	555
700	600	14.4	14.4	1200	600
800	200	15.6	8.4	690	585
800	400	15.6	10.8	910	615
800	600	15.6	13.2	1350	645
800	800	15.6	15.6	1350	675
900	200	16.8	8.4	730	645
900	400	16.8	10.8	950	675
900	600	16.8	13.2	1500	705
1000	200	18.0	8.4	770	705
1000	400	18.0	10.8	990	735
1000	600	18.0	13.2	1650	765
1000	1000	18.0	18.0	1650	825

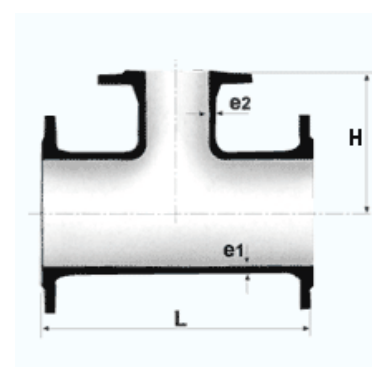

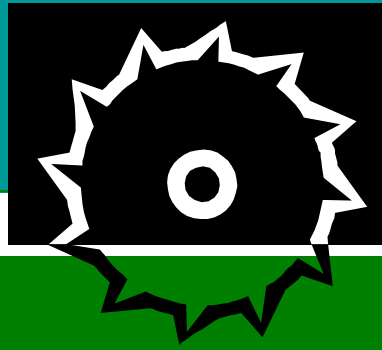

almanit sanitary fittings
Wartenau 7 22089 Hamburg Germany
Tel.: +49 40 2513347 Fax: +49 40 2513681